



COMMONWEALTH OF PENNSYLVANIA  
DEPARTMENT OF ENVIRONMENTAL PROTECTION  
AIR QUALITY PROGRAM

**STATE ONLY NATURAL MINOR OPERATING PERMIT**

Issue Date: September 24, 2024

Effective Date: September 24, 2024

Expiration Date: September 23, 2029

In accordance with the provisions of the Air Pollution Control Act, the Act of January 8, 1960, P.L. 2119, as amended, and 25 Pa. Code Chapter 127, the Owner, [and Operator if noted] (hereinafter referred to as permittee) identified below is authorized by the Department of Environmental Protection (Department) to operate the air emission source(s) more fully described in this permit. This Facility is subject to all terms and conditions specified in this permit. Nothing in this permit relieves the permittee from its obligations to comply with all applicable Federal, State and Local laws and regulations.

The regulatory or statutory authority for each permit condition is set forth in brackets. All terms and conditions in this permit are federally enforceable unless otherwise designated.

**State Only Permit No: 49-00005**

Natural Minor

Federal Tax Id - Plant Code: 13-1656308-1

**Owner Information**

Name: HOEGANAES CORP  
Mailing Address: 4330 PARADISE RD  
WATSONTOWN, PA 17777-8802

**Plant Information**

Plant: HOEGANAES CORP/WATSONTOWN PLT  
Location: 49 Northumberland County 49909 Delaware Township  
SIC Code: 3399 Manufacturing - Primary Metal Products, Nec

**Responsible Official**

Name: DARREN E BOOP  
Title: PLANT MANAGER  
Phone: (570) 337 - 1719 Email: Darren.boop@hoeganaes.com

**Permit Contact Person**

Name: DARREN E BOOP  
Title: PLANT MANAGER  
Phone: (570) 337 - 1719 Email: Darren.boop@hoeganaes.com

[Signature] \_\_\_\_\_

MUHAMMAD Q. ZAMAN, ENVIRONMENTAL PROGRAM MANAGER, NORTHCENTRAL REGION



## SECTION A. Table of Contents

### Section A. Facility/Source Identification

Table of Contents  
Site Inventory List

### Section B. General State Only Requirements

- #001 Definitions.
- #002 Operating Permit Duration.
- #003 Permit Renewal.
- #004 Operating Permit Fees under Subchapter I.
- #005 Transfer of Operating Permits.
- #006 Inspection and Entry.
- #007 Compliance Requirements.
- #008 Need to Halt or Reduce Activity Not a Defense.
- #009 Duty to Provide Information.
- #010 Revising an Operating Permit for Cause.
- #011 Operating Permit Modifications
- #012 Severability Clause.
- #013 De Minimis Emission Increases.
- #014 Operational Flexibility.
- #015 Reactivation of Sources
- #016 Health Risk-based Emission Standards and Operating Practice Requirements.
- #017 Circumvention.
- #018 Reporting Requirements.
- #019 Sampling, Testing and Monitoring Procedures.
- #020 Recordkeeping.
- #021 Property Rights.
- #022 Alternative Operating Scenarios.
- #023 Reporting
- #024 Report Format

### Section C. Site Level State Only Requirements

- C-I: Restrictions
- C-II: Testing Requirements
- C-III: Monitoring Requirements
- C-IV: Recordkeeping Requirements
- C-V: Reporting Requirements
- C-VI: Work Practice Standards
- C-VII: Additional Requirements
- C-VIII: Compliance Certification
- C-IX: Compliance Schedule

### Section D. Source Level State Only Requirements

- D-I: Restrictions
- D-II: Testing Requirements
- D-III: Monitoring Requirements
- D-IV: Recordkeeping Requirements
- D-V: Reporting Requirements
- D-VI: Work Practice Standards
- D-VII: Additional Requirements

Note: These same sub-sections are repeated for each source!

### Section E. Source Group Restrictions

- E-I: Restrictions



## **SECTION A. Table of Contents**

- E-II: Testing Requirements
- E-III: Monitoring Requirements
- E-IV: Recordkeeping Requirements
- E-V: Reporting Requirements
- E-VI: Work Practice Standards
- E-VII: Additional Requirements

### **Section F. Alternative Operating Scenario(s)**

- F-I: Restrictions
- F-II: Testing Requirements
- F-III: Monitoring Requirements
- F-IV: Recordkeeping Requirements
- F-V: Reporting Requirements
- F-VI: Work Practice Standards
- F-VII: Additional Requirements

### **Section G. Emission Restriction Summary**

### **Section H. Miscellaneous**

**SECTION A. Site Inventory List**

Source ID	Source Name	Capacity/Throughput	Fuel/Material
031	2 BOILERS (BOILER B101 & WAREHOUSE BOILER)		
034	SAMPLE SINTERING FURNACE		
035	25 SPACE HEATERS		
P101	METL POWD BLEND & BOND OPERATIONS		
P106	METL POWD MANUFACT OPERATION		
P109	SPECIALTY BLENDED METALS PROCESS		
P112	AGM DELIVERY SYSTEM		
P113	DISTALOY SCREEN SYSTEM		
P121	SAMPLE PRODUCTION PROCESS		
P122	50 KW EMERGENCY GENERATOR		
C1	MAJ ADD CARTRIDGE COLLECTOR		
C112A	EVACUATION BAG FILTER (F1) & BUSCH VACUUM FILTERS		
C112B	FABRIC COLLECTOR (B1) & BUSCH VACUUM FILTERS		
C113A	DISCHARGE HOPPER & SCREEN FABRIC COLLECTOR & HEPA		
C113B	PACK-OUT STATIONS FABRIC COLLECTOR & HEPA		
C115	DONALDSON DFE 2-4 CARTRIDGE COLLECTOR		
C2	METAL POWD CARTRIDGE COLLECTOR		
C23	METAL POWD COAT TANK COOLING COILS		
C24	METAL POWD BOND CONDENSERS (2)		
C26	METAL POWD BOND CONDENSER (1)		
C3	METAL POWD CARTRIDGE COLLECTR		
C36	GENERAL CARTRIDGE COLLECTOR		
C37	BASE IRON UNL. HOPP. CARTRIDGE COLLECTOR		
C38	4 CARBON SILO BIN VENT CARTRIDGE COLLECTORS		
C39	CARBON UNL. HOPPER CARTRIDGE COLLECTOR		
C4	METL POWD MANUF (1) CRTDGE CLLCTR		
C40	MIXER BIN VENT FABRIC COLLECTOR		
C41	MAC 2M2F8 PULSE JET CARTRIDGE COLLECTOR		
FM01	15,000 GAL #2 OIL/KEROSENE TANK		
FM02	10,000 GAL #2 OIL/KEROSENE TANK		
FM03	6,000 GAL #2 OIL/KEROSENE TANK		
FM04	HYDROGEN/PROPANE FUEL TANK		
S031	WAREHOUSE BOILER STACK		
S031A	BOILER B101 STACK		
S035	SPACE HEATER STACKS		
S101A	MAJOR ADDITIVE FILL STACK		
S101B	MINOR ADDITIVE FILL STACK		
S101C	BLENDING COLLECTOR STACK		
S106	POWD METL MANU CLLTR STKS		

**SECTION A. Site Inventory List**

Source ID	Source Name	Capacity/Throughput	Fuel/Material
S106A	POWD METL MANU BOILER STK		
S110	GENERAL CARTRIDGE COLLECTOR STACK		
S111	BASE IRON UNL.HOPP. CARTRIDGE COLLECTOR STACK		
S112	4 CARBON SILO BIN VENT CARTRIDGE COLLECTORS STACK		
S113	CARBON UNL. HOPPER CARTRIDGE COLLECTOR STACK		
S114	MIXER BIN VENT FABRIC COLLECTOR STACK		
S122	STACK		
S41	STACK FOR CARTRIDGE COLLECTOR		
Z034	SINTERING FURNACE INDOOR VENT		
Z101	BL&BND COIL/CON EMISSIONS		
Z112A	EVACUATION BAG FILTER (F1) & BUSCH FILTERS EXHAUST		
Z112B	FABRIC COLLECTOR (B1) AND BUSCH FILTERS EXHAUST		
Z113A	DISCHARGE HOPPER & SCREEN FABRIC COLLECTOR & HEPA EXHAUST		
Z113B	PACK-OUT STATIONS FABRIC COLLECTOR & HEPA EXHAUST		

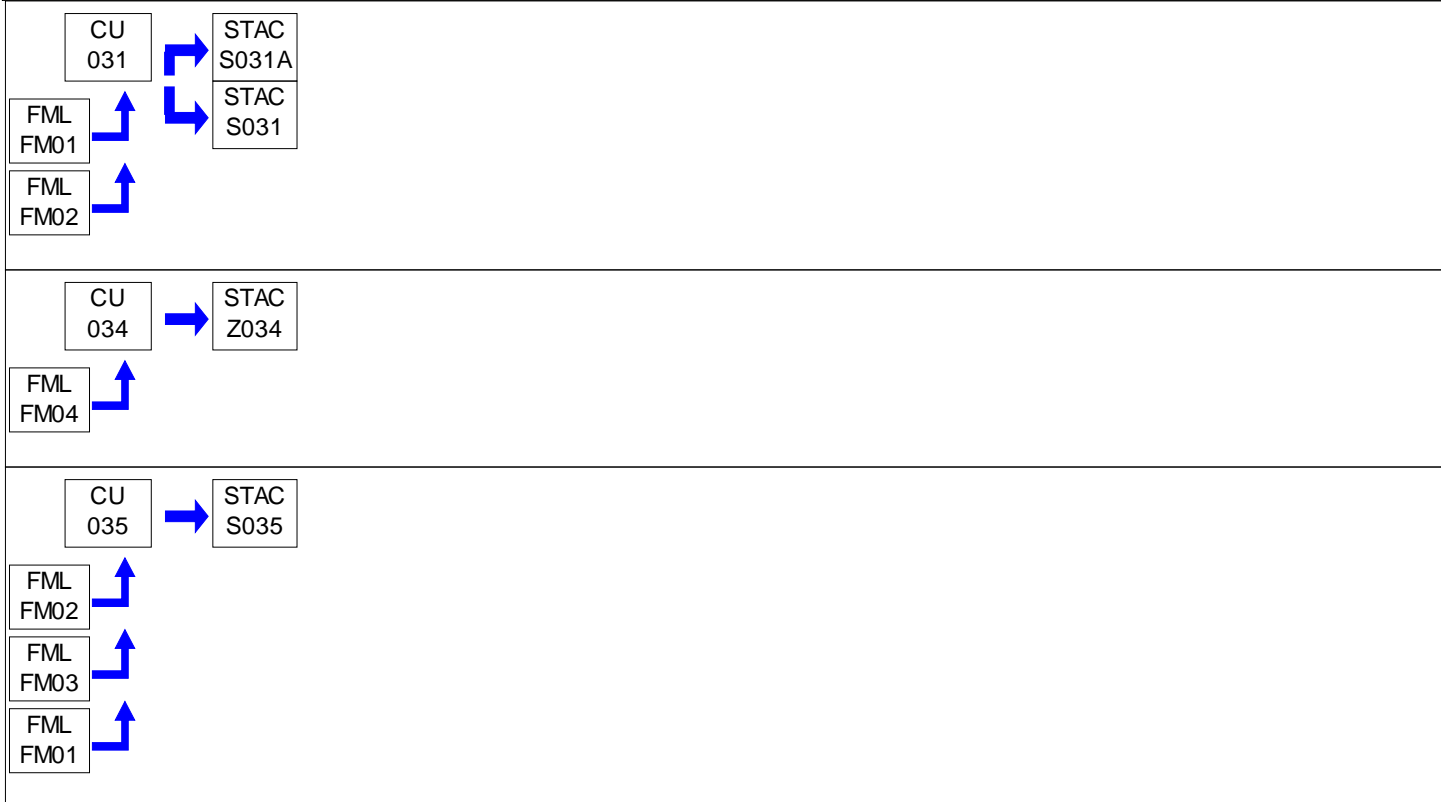
**PERMIT MAPS**



PERMIT MAPS

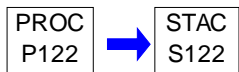
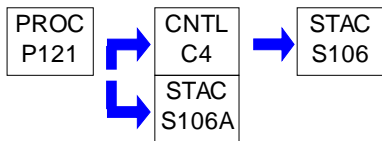
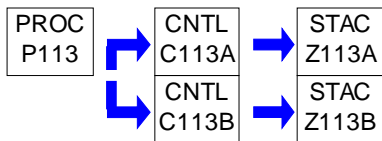
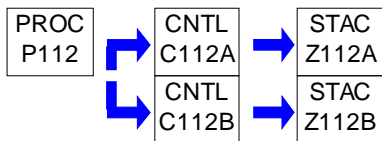
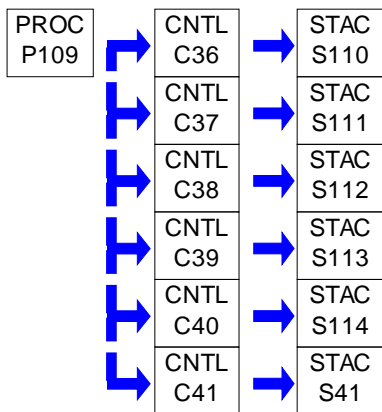
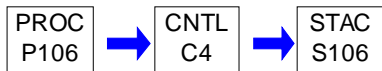
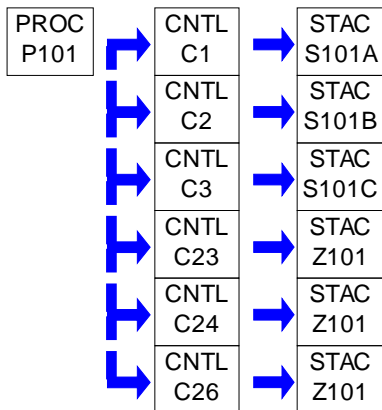

**SECTION B. General State Only Requirements****#001 [25 Pa. Code § 121.1]****Definitions.**

Words and terms that are not otherwise defined in this permit shall have the meanings set forth in Section 3 of the Air Pollution Control Act (35 P.S. § 4003) and in 25 Pa. Code § 121.1.

**#002 [25 Pa. Code § 127.446]****Operating Permit Duration.**

(a) This operating permit is issued for a fixed term of five (5) years and shall expire on the date specified on Page 1 of this permit.

(b) The terms and conditions of the expired permit shall automatically continue pending issuance of a new operating permit, provided the permittee has submitted a timely and complete application and paid applicable fees required under 25 Pa. Code Chapter 127, Subchapter I and the Department is unable, through no fault of the permittee, to issue or deny a new permit before the expiration of the previous permit.

**#003 [25 Pa. Code §§ 127.412, 127.413, 127.414, 127.446 & 127.703(b)]****Permit Renewal.**

(a) The permittee shall submit a timely and complete application for renewal of the operating permit to the appropriate Regional Air Program Manager. The application for renewal of the operating permit shall be submitted at least six (6) months and not more than 18 months before the expiration date of this permit.

(b) The application for permit renewal shall include the current permit number, a description of any permit revisions that occurred during the permit term, and any applicable requirements that were promulgated and not incorporated into the permit during the permit term. An application is complete if it contains sufficient information to begin processing the application, has the applicable sections completed and has been signed by a responsible official.

(c) The permittee shall submit with the renewal application a fee for the processing of the application as specified in 25 Pa. Code § 127.703(b). The fees shall be made payable to "The Commonwealth of Pennsylvania Clean Air Fund" and submitted with the fee form to the respective regional office.

(d) The renewal application shall also include submission of proof that the local municipality and county, in which the facility is located, have been notified in accordance with 25 Pa. Code § 127.413.

(e) The application for renewal of the operating permit shall also include submission of supplemental compliance review forms in accordance with the requirements of 25 Pa. Code § 127.412(b) and § 127.412(j).

(f) The permittee, upon becoming aware that any relevant facts were omitted or incorrect information was submitted in the permit application, shall promptly submit such supplementary facts or corrected information as necessary to address any requirements that become applicable to the source after the permittee submits a complete application, but prior to the date the Department takes action on the permit application.

**#004 [25 Pa. Code § 127.703]****Operating Permit Fees under Subchapter I.**

(a) The permittee shall pay the annual operating permit maintenance fee according to the following fee schedule in either paragraph (1) or (2) in accordance with 25 Pa. Code § 127.703(d) on or before December 31 of each year for the next calendar year.

(1) For a synthetic minor facility, a fee equal to:

(i) Four thousand dollars (\$4,000) for calendar years 2021—2025.

(ii) Five thousand dollars (\$5,000) for calendar years 2026—2030.

(iii) Six thousand three hundred dollars (\$6,300) for the calendar years beginning with 2031.

**SECTION B. General State Only Requirements**

(2) For a facility that is not a synthetic minor, a fee equal to:

- (i) Two thousand dollars (\$2,000) for calendar years 2021—2025.
- (ii) Two thousand five hundred dollars (\$2,500) for calendar years 2026—2030.
- (iii) Three thousand one hundred dollars (\$3,100) for the calendar years beginning with 2031.

(b) The applicable fees shall be made payable to "The Commonwealth of Pennsylvania Clean Air Fund" with the permit number clearly indicated and submitted to the respective regional office.

**#005 [25 Pa. Code §§ 127.450 (a)(4) and 127.464]****Transfer of Operating Permits.**

(a) This operating permit may not be transferred to another person, except in cases of transfer-of-ownership that are documented and approved by the Department.

(b) In accordance with 25 Pa. Code § 127.450(a)(4), a change in ownership of the source shall be treated as an administrative amendment if the Department determines that no other change in the permit is required and a written agreement has been submitted to the Department identifying the specific date of the transfer of permit responsibility, coverage and liability between the current and the new permittee and a compliance review form has been submitted to, and the permit transfer has been approved by, the Department.

(c) This operating permit is valid only for those specific sources and the specific source locations described in this permit.

**#006 [25 Pa. Code § 127.441 and 35 P.S. § 4008]****Inspection and Entry.**

(a) Upon presentation of credentials and other documents as may be required by law, the permittee shall allow the Department or authorized representatives of the Department to perform the following:

(1) Enter at reasonable times upon the permittee's premises where a source is located or emissions related activity is conducted, or where records are kept under the conditions of this permit;

(2) Have access to and copy, at reasonable times, any records that are kept under the conditions of this permit;

(3) Inspect at reasonable times, any facilities, equipment including monitoring and air pollution control equipment, practices, or operations regulated or required under this permit;

(4) Sample or monitor, at reasonable times, any substances or parameters, for the purpose of assuring compliance with the permit or applicable requirements as authorized by the Clean Air Act, the Air Pollution Control Act, or the regulations promulgated under the Acts.

(b) Pursuant to 35 P.S. § 4008, no person shall hinder, obstruct, prevent or interfere with the Department or its personnel in the performance of any duty authorized under the Air Pollution Control Act or regulations adopted thereunder including denying the Department access to a source at this facility. Refusal of entry or access may constitute grounds for permit revocation and assessment of criminal and/or civil penalties.

(c) Nothing in this permit condition shall limit the ability of the EPA to inspect or enter the premises of the permittee in accordance with Section 114 or other applicable provisions of the Clean Air Act.

**#007 [25 Pa. Code §§ 127.441 & 127.444]****Compliance Requirements.**

(a) The permittee shall comply with the conditions of this operating permit. Noncompliance with this permit constitutes a violation of the Clean Air Act and the Air Pollution Control Act and is grounds for one or more of the following:



**SECTION B. General State Only Requirements**

- (1) Enforcement action
- (2) Permit termination, revocation and reissuance or modification
- (3) Denial of a permit renewal application

(b) A person may not cause or permit the operation of a source which is subject to 25 Pa. Code Article III unless the source(s) and air cleaning devices identified in the application for the plan approval and operating permit and the plan approval issued for the source is operated and maintained in accordance with specifications in the applications and the conditions in the plan approval and operating permit issued by the Department. A person may not cause or permit the operation of an air contamination source subject to 25 Pa. Code Chapter 127 in a manner inconsistent with good operating practices.

(c) For purposes of Sub-condition (b) of this permit condition, the specifications in applications for plan approvals and operating permits are the physical configurations and engineering design details which the Department determines are essential for the permittee's compliance with the applicable requirements in this State-Only permit. Nothing in this sub-condition shall be construed to create an independent affirmative duty upon the permittee to obtain a predetermination from the Department for physical configuration or engineering design detail changes made by the permittee.

**#008 [25 Pa. Code § 127.441]****Need to Halt or Reduce Activity Not a Defense.**

It shall not be a defense for the permittee in an enforcement action that it was necessary to halt or reduce the permitted activity in order to maintain compliance with the conditions of this permit.

**#009 [25 Pa. Code §§ 127.442(a) & 127.461]****Duty to Provide Information.**

(a) The permittee shall submit reports to the Department containing information the Department may prescribe relative to the operation and maintenance of each source at the facility.

(b) The permittee shall furnish to the Department, in writing, information that the Department may request to determine whether cause exists for modifying, revoking and reissuing, or terminating this permit, or to determine compliance with the permit. Upon request, the permittee shall also furnish to the Department copies of records that the permittee is required to maintain in accordance with this permit.

**#010 [25 Pa. Code § 127.461]****Revising an Operating Permit for Cause.**

This operating permit may be terminated, modified, suspended or revoked and reissued if one or more of the following applies:

- (1) The permittee constructs or operates the source subject to the operating permit so that it is in violation of the Air Pollution Control Act, the Clean Air Act, the regulations thereunder, a plan approval, a permit or in a manner that causes air pollution.
- (2) The permittee fails to properly or adequately maintain or repair an air pollution control device or equipment attached to or otherwise made a part of the source.
- (3) The permittee has failed to submit a report required by the operating permit or an applicable regulation.
- (4) The EPA determines that the permit is not in compliance with the Clean Air Act or the regulations thereunder.

**#011 [25 Pa. Code §§ 127.450, 127.462, 127.465 & 127.703]****Operating Permit Modifications**

(a) The permittee is authorized to make administrative amendments, minor operating permit modifications and significant operating permit modifications, under this permit, as outlined below:

**SECTION B. General State Only Requirements**

(b) Administrative Amendments. The permittee shall submit the application for administrative operating permit amendments (as defined in 25 Pa. Code § 127.450(a)), according to procedures specified in § 127.450 unless precluded by the Clean Air Act or its regulations.

(c) Minor Operating Permit Modifications. The permittee shall submit the application for minor operating permit modifications (as defined 25 Pa. Code § 121.1) in accordance with 25 Pa. Code § 127.462.

(d) Significant Operating Permit Modifications. The permittee shall submit the application for significant operating permit modifications in accordance with 25 Pa. Code § 127.465.

(e) The applicable fees shall be made payable to "The Commonwealth of Pennsylvania Clean Air Fund" with the permit number clearly indicated and submitted to the respective regional office.

**#012 [25 Pa. Code § 127.441]****Severability Clause.**

The provisions of this permit are severable, and if any provision of this permit is determined by a court of competent jurisdiction to be invalid or unenforceable, such a determination will not affect the remaining provisions of this permit.

**#013 [25 Pa. Code § 127.449]****De Minimis Emission Increases.**

(a) This permit authorizes de minimis emission increases in accordance with 25 Pa. Code § 127.449 so long as the permittee provides the Department with seven (7) days prior written notice before commencing any de minimis emissions increase. The written notice shall:

(1) Identify and describe the pollutants that will be emitted as a result of the de minimis emissions increase.

(2) Provide emission rates expressed in tons per year and in terms necessary to establish compliance consistent with any applicable requirement.

(b) The Department may disapprove or condition de minimis emission increases at any time.

(c) Except as provided below in (d), the permittee is authorized to make de minimis emission increases (expressed in tons per year) up to the following amounts without the need for a plan approval or prior issuance of a permit modification:

(1) Four tons of carbon monoxide from a single source during the term of the permit and 20 tons of carbon monoxide at the facility during the term of the permit.

(2) One ton of NO<sub>x</sub> from a single source during the term of the permit and 5 tons of NO<sub>x</sub> at the facility during the term of the permit.

(3) One and six-tenths tons of the oxides of sulfur from a single source during the term of the permit and 8.0 tons of oxides of sulfur at the facility during the term of the permit.

(4) Six-tenths of a ton of PM<sub>10</sub> from a single source during the term of the permit and 3.0 tons of PM<sub>10</sub> at the facility during the term of the permit. This shall include emissions of a pollutant regulated under Section 112 of the Clean Air Act unless precluded by the Clean Air Act, the regulations thereunder or 25 Pa. Code Article III.

(5) One ton of VOCs from a single source during the term of the permit and 5.0 tons of VOCs at the facility during the term of the permit. This shall include emissions of a pollutant regulated under Section 112 of the Clean Air Act unless precluded by the Clean Air Act, the regulations thereunder or 25 Pa. Code Article III.

(6) Other sources and classes of sources determined to be of minor significance by the Department.

(d) In accordance with § 127.14, the permittee is authorized to install the following minor sources without the need for a plan approval or permit modification:

**SECTION B. General State Only Requirements**

- (1) Air conditioning or ventilation systems not designed to remove pollutants generated or released from other sources.
  - (2) Combustion units rated at 2,500,000 or less Btu per hour of heat input.
  - (3) Combustion units with a rated capacity of less than 10,000,000 Btu per hour heat input fueled by natural gas supplied by a public utility or by commercial fuel oils which are No. 2 or lighter, viscosity less than or equal to 5.82 c St, and which meet the sulfur content requirements of 25 Pa. Code §123.22 (relating to combustion units). For purposes of this permit, commercial fuel oil shall be virgin oil which has no reprocessed, recycled or waste material added.
  - (4) Space heaters which heat by direct heat transfer.
  - (5) Laboratory equipment used exclusively for chemical or physical analysis.
  - (6) Other sources and classes of sources determined to be of minor significance by the Department.
- (e) This permit does not authorize de minimis emission increases if the emissions increase would cause one or more of the following:
- (1) Increase the emissions of a pollutant regulated under Section 112 of the Clean Air Act except as authorized in Subparagraphs (c)(4) and (5) of this permit condition.
  - (2) Subject the facility to the prevention of significant deterioration requirements in 25 Pa. Code Chapter 127, Subchapter D and/or the new source review requirements in Subchapter E.
  - (3) Violate any applicable requirement of this permit, the Air Pollution Control Act, the Clean Air Act, or the regulations promulgated under either of the acts.
- (f) Emissions authorized under this permit condition shall be included in the monitoring, recordkeeping and reporting requirements of this permit.
- (g) Except for de minimis emission increases, installation of minor sources made pursuant to this permit condition and Plan Approval Exemptions under 25 Pa. Code § 127.14 (relating to exemptions), the permittee is prohibited from making changes or engaging in activities that are not specifically authorized under this permit without first applying for a plan approval. In accordance with § 127.14(b), a plan approval is not required for the construction, modification, reactivation, or installation of the sources creating the de minimis emissions increase.
- (h) The permittee may not meet de minimis emission threshold levels by offsetting emission increases or decreases at the same source.

**#014 [25 Pa. Code § 127.3]****Operational Flexibility.**

The permittee is authorized to make changes within the facility in accordance with the regulatory provisions outlined in 25 Pa. Code § 127.3 (relating to operational flexibility) to implement the operational flexibility requirements provisions authorized under Section 6.1(i) of the Air Pollution Control Act and the operational flexibility terms and conditions of this permit. The provisions in 25 Pa. Code Chapter 127 which implement the operational flexibility requirements include the following:

- (1) Section 127.14 (relating to exemptions)
- (2) Section 127.447 (relating to alternative operating scenarios)
- (3) Section 127.448 (relating to emissions trading at facilities with Federally enforceable emissions caps)
- (4) Section 127.449 (relating to de minimis emission increases)
- (5) Section 127.450 (relating to administrative operating permit amendments)

**SECTION B. General State Only Requirements**

(6) Section 127.462 (relating to minor operating permit modifications)

(7) Subchapter H (relating to general plan approvals and general operating permits)

**#015 [25 Pa. Code § 127.11a]****Reactivation of Sources**

(a) The permittee may not reactivate a source that has been out of operation or production for at least one year unless the reactivation is conducted in accordance with a plan approval granted by the Department or in accordance with reactivation and maintenance plans developed and approved by the Department in accordance with 25 Pa. Code § 127.11a(a).

(b) A source which has been out of operation or production for more than five (5) years but less than 10 years may be reactivated and will not be considered a new source if the permittee satisfies the conditions specified in 25 Pa. Code § 127.11a(b).

**#016 [25 Pa. Code § 127.36]****Health Risk-based Emission Standards and Operating Practice Requirements.**

(a) When needed to protect public health, welfare and the environment from emissions of hazardous air pollutants from new and existing sources, the permittee shall comply with the health risk-based emission standards or operating practice requirements imposed by the Department, except as precluded by §§ 6.6(d)(2) and (3) of the Air Pollution Control Act [35 P.S. § 4006.6(d)(2) and (3)].

(b) A person challenging a performance or emission standard established by the Department has the burden to demonstrate that performance or emission standard does not meet the requirements of Section 112 of the Clean Air Act.

**#017 [25 Pa. Code § 121.9]****Circumvention.**

No person may permit the use of a device, stack height which exceeds good engineering practice stack height, dispersion technique or other technique which, without resulting in reduction of the total amount of air contaminants emitted, conceals or dilutes an emission of air contaminants which would otherwise be in violation of 25 Pa. Code Article III, except that with prior approval of the Department, the device or technique may be used for control of malodors.

**#018 [25 Pa. Code §§ 127.402(d) & 127.442]****Reporting Requirements.**

(a) The permittee shall comply with the applicable reporting requirements of the Clean Air Act, the regulations thereunder, the Air Pollution Control Act and 25 Pa. Code Article III including Chapters 127, 135 and 139.

(b) The permittee shall submit reports to the Department containing information the Department may prescribe relative to the operation and maintenance of any air contamination source.

(c) Reports, test data, monitoring data, notifications and requests for renewal of the permit shall be submitted to the:

Regional Air Program Manager  
PA Department of Environmental Protection  
(At the address given in the permit transmittal letter, or otherwise notified)

(d) Any records or information including applications, forms, or reports submitted pursuant to this permit condition shall contain a certification by a responsible official as to truth, accuracy and completeness. The certifications submitted under this permit shall require a responsible official of the facility to certify that based on information and belief formed after reasonable inquiry, the statements and information in the documents are true, accurate and complete.

(e) Any records, reports or information submitted to the Department shall be available to the public except for such

**SECTION B. General State Only Requirements**

records, reports or information which meet the confidentiality requirements of § 4013.2 of the Air Pollution Control Act and §§ 112(d) and 114(c) of the Clean Air Act. The permittee may not request a claim of confidentiality for any emissions data generated for the facility.

**#019 [25 Pa. Code §§ 127.441(c) & 135.5]****Sampling, Testing and Monitoring Procedures.**

(a) The permittee shall comply with the monitoring, recordkeeping or reporting requirements of 25 Pa. Code Chapter 139 and the other applicable requirements of 25 Pa. Code Article III and additional requirements related to monitoring, reporting and recordkeeping required by the Clean Air Act and the regulations thereunder including the Compliance Assurance Monitoring requirements of 40 CFR Part 64, where applicable.

(b) Unless alternative methodology is required by the Clean Air Act and regulations adopted thereunder, sampling, testing and monitoring required by or used by the permittee to demonstrate compliance with any applicable regulation or permit condition shall be conducted in accordance with the requirements of 25 Pa. Code Chapter 139.

**#020 [25 Pa. Code §§ 127.441(c) and 135.5]****Recordkeeping.**

(a) The permittee shall maintain and make available, upon request by the Department, the following records of monitored information:

- (1) The date, place (as defined in the permit) and time of sampling or measurements.
- (2) The dates the analyses were performed.
- (3) The company or entity that performed the analyses.
- (4) The analytical techniques or methods used.
- (5) The results of the analyses.
- (6) The operating conditions as existing at the time of sampling or measurement.

(b) The permittee shall retain records of any required monitoring data and supporting information for at least five (5) years from the date of the monitoring, sample, measurement, report or application. Supporting information includes the calibration data and maintenance records and original strip-chart recordings for continuous monitoring instrumentation, and copies of reports required by the permit.

(c) The permittee shall maintain and make available to the Department upon request, records including computerized records that may be necessary to comply with the reporting, recordkeeping and emission statement requirements in 25 Pa. Code Chapter 135 (relating to reporting of sources). In accordance with 25 Pa. Code Chapter 135, § 135.5, such records may include records of production, fuel usage, maintenance of production or pollution control equipment or other information determined by the Department to be necessary for identification and quantification of potential and actual air contaminant emissions.

**#021 [25 Pa. Code § 127.441(a)]****Property Rights.**

This permit does not convey any property rights of any sort, or any exclusive privileges.

**#022 [25 Pa. Code § 127.447]****Alternative Operating Scenarios.**

The permittee is authorized to make changes at the facility to implement alternative operating scenarios identified in this permit in accordance with 25 Pa. Code § 127.447.

**SECTION B. General State Only Requirements****#023 [25 Pa. Code §135.3]****Reporting**

(a) If the facility is a Synthetic Minor Facility, the permittee shall submit by March 1 of each year an annual emissions report for the preceding calendar year. The report shall include information for all active previously reported sources, new sources which were first operated during the preceding calendar year, and sources modified during the same period which were not previously reported. All air emissions from the facility should be estimated and reported.

(b) A source owner or operator of a Synthetic Minor Facility may request an extension of time from the Department for the filing of an annual emissions report, and the Department may grant the extension for reasonable cause.

**#024 [25 Pa. Code §135.4]****Report Format**

If applicable, the emissions reports shall contain sufficient information to enable the Department to complete its emission inventory. Emissions reports shall be made by the source owner or operator in a format specified by the Department.

**SECTION C. Site Level Requirements****I. RESTRICTIONS.****Emission Restriction(s).****# 001 [25 Pa. Code §123.1]****Prohibition of certain fugitive emissions**

No person may permit the emission into the outdoor atmosphere of fugitive air contaminants from a source other than the following:

- (1) Construction or demolition of buildings or structures
- (2) Grading, paving and maintenance of roads and streets
- (3) Use of roads and streets. Emissions from material in or on trucks, railroad cars and other vehicular equipment are not considered as emissions from use of roads and streets.
- (4) Clearing of land
- (5) Stockpiling of materials.
- (6) Open burning operations.
- (7) Sources and classes of sources other than those identified above, for which the permittee has obtained a determination from the Department that fugitive emissions from the source, after appropriate control, meet the following requirements:
  - (i) The emissions are of minor significance with respect to causing air pollution.
  - (ii) The emissions are not preventing or interfering with the attainment or maintenance of any ambient air quality standard.

**# 002 [25 Pa. Code §123.2]****Fugitive particulate matter**

No person may permit fugitive particulate matter to be emitted into the outdoor atmosphere from a source specified in Condition #001 above if the emissions are visible at the point the emissions pass outside the person's property.

**# 003 [25 Pa. Code §123.41]****Limitations**

No person may permit the emission into the outdoor atmosphere of visible air contaminants in such a manner that the opacity of the emission is either of the following:

- (1) Equal to or greater than 20% for a period or periods aggregating more than three minutes in any 1 hour.
- (2) Equal to or greater than 60% at any time.

**# 004 [25 Pa. Code §123.42]****Exceptions**

The emission limitations of 25 Pa. Code Section 123.41 shall not apply when:

- (1) The presence of uncombined water is the only reason for failure of the emission to meet the limitations;
- (2) The emission results from the operation of equipment used solely to train and test persons in observing the opacity of visible emissions;
- (3) The emission results from sources specified in 25 Pa. Code Section 123.1(a)(1)-(9).

**SECTION C. Site Level Requirements****Fuel Restriction(s).****# 005 [25 Pa. Code §127.441]****Operating permit terms and conditions.**

[Additional authority for this permit condition is derived from 25 Pa. Code Section 123.22(a)(2)]

The sulfur content of the #2 and lighter oil used in combustion sources at the facility shall not, at any time, exceed 0.0015% by weight. In addition, any #2 or lighter fuel oil burned shall be virgin fuel to which no reclaimed or waste oil or other waste materials have been added.

**II. TESTING REQUIREMENTS.****# 006 [25 Pa. Code §127.441]****Operating permit terms and conditions.**

- (a) Pursuant to 25 Pa. Code § 139.3, at least 90 calendar days prior to commencing a EPA reference method testing program, a test protocol shall be submitted to the Department for review and approval. One electronic copy shall be sent to the Northcentral Regional Office Air Quality Program Manager (RA-EPNCstacktesting@pa.gov) and one electronic copy shall be sent to the PSIMS Administrator in Central Office (RA-EPstacktesting@pa.gov). The test protocol shall meet all applicable requirements specified in the most current version of the Department's Source Testing Manual.
- (b) Pursuant to 25 Pa. Code § 139.3, at least 15 calendar days prior to commencing an emission testing program, notification as to the date and time of testing shall be given to the Northcentral Regional Office. Notification shall also be sent to the Division of Source Testing and Monitoring. Notification shall not be made without prior receipt of a protocol acceptance letter from the Department.
- (c) Within sixty (60) days of the completion of the stack tests required by this permit, an electronically submitted copy of the report in .pdf format shall be submitted to the Department. This report shall contain the results of the tests, a description of the testing and analytical procedures actually used in performance of the tests, all process and operating data collected during the tests, a copy of all raw data, and a copy of all calculations generated during data analysis.
- (d) Pursuant to 25 Pa. Code § 139.53(b) a complete test report shall include a summary of the emission results on the first page of the report indicating if each pollutant measured is within permitted limits and a statement of compliance or noncompliance with all applicable permit conditions. The summary results will include, at a minimum, the following information:
1. A statement that the owner or operator has reviewed the report from the emissions testing body and agrees with the findings.
  2. Permit number(s) and condition(s) which are the basis for the evaluation.
  3. Summary of results with respect to each applicable permit condition.
  4. Statement of compliance or non-compliance with each applicable permit condition.
- (e) Pursuant to 25 Pa. Code § 139.3, all submittals shall meet all applicable requirements specified in the most current version of the Department's Source Testing Manual.
- (f) All testing shall be performed in accordance with the provisions of Chapter 139 of the Rules and Regulations of the Department of Environmental Protection.
- (g) Pursuant to 25 Pa. Code § § 139.53(a)(1) and 139.53(a)(3), one electronic copy of all submittals, besides notifications, shall be sent to the Northcentral Regional Office Air Quality Program Manager. In addition, one electronic copy shall be sent to the PSIMS Administrator in Central Office using the emails above when the file is 35 MB or less, or a flash drive when the file is over 35 MB.
- (h) The permittee shall insure all federal reporting requirements contained in the applicable subpart of 40 CFR are followed, including timelines more stringent than those contained herein. In the event of an inconsistency or any conflicting requirements between state and the federal, the most stringent provision, term, condition, method or rule shall be used by default.



**SECTION C. Site Level Requirements****# 007 [25 Pa. Code §127.441]****Operating permit terms and conditions.**

The permittee shall perform tests (in accordance with the provisions of 25 Pa. Code Chapter 139) or provide a fuel analysis report of the percent sulfur by weight for each delivery of the #2 and lighter oil delivered to this facility,

OR

The permittee shall provide a fuel analysis report obtained from the supplier once a year stating that the sulfur percentage for each shipment of #2 and lighter oil delivered to the facility during the year shall not exceed 0.0015% sulfur by weight.

**# 008 [25 Pa. Code §139.1]****Sampling facilities.**

Upon the request of the Department, the permittee shall provide adequate sampling ports, safe sampling platforms and adequate utilities for the performance by the Department of tests on such source. The Department will set forth, in the request, the time period in which the facilities shall be provided as well as the specifications for such facilities.

**# 009 [25 Pa. Code §139.11]****General requirements.**

(a) As specified in 25 Pa. Code Section 139.11(1), performance tests shall be conducted while the source is operating at maximum routine operating conditions or under such other conditions, within the capacity of the equipment, as may be requested by the Department.

(b) As specified in 25 Pa. Code Section 139.11(2), the Department will consider test results for approval where sufficient information is provided to verify the source conditions existing at the time of the test and where adequate data is available to show the manner in which the test was conducted. Information submitted to the Department shall include, as a minimum, all of the following:

- (1) A thorough source description, including a description of any air cleaning devices and the flue.
- (2) Process conditions, for example, the charging rate of raw material or rate of production of final product, boiler pressure, oven temperature and other conditions which may effect emissions from the process.
- (3) The location of sampling ports.
- (4) Effluent characteristics, including velocity, temperature, moisture content, gas density (percentage of CO, CO<sub>2</sub>, O<sub>2</sub> and N<sub>2</sub>), static and barometric pressures.
- (5) Sample collection techniques employed, including procedures used, equipment descriptions and data to verify that isokinetic sampling for particulate matter collection occurred and that acceptable test conditions were met.
- (6) Laboratory procedures and results.
- (7) Calculated results.

**III. MONITORING REQUIREMENTS.****# 010 [25 Pa. Code §123.43]****Measuring techniques**

Visible emissions may be measured using either of the following:

- (1) A device approved by the Department and maintained to provide accurate opacity measurements.
- (2) Observers, trained and qualified, to measure plume opacity with the naked eye or with the aid of any devices approved

**SECTION C. Site Level Requirements**

by the Department.

**# 011 [25 Pa. Code §127.441]****Operating permit terms and conditions.**

(a) The permittee shall conduct a weekly inspection of the facility during daylight hours while the facility is operating to detect visible emissions, visible fugitive emissions and malodors. Weekly inspections are necessary to determine:

- (1) The presence of visible emissions.
- (2) The presence of visible fugitive emissions.
- (3) The presence of malodors beyond the boundaries of the facility.

(b) All detected visible emissions, visible fugitive emissions or malodors that have the potential to exceed applicable limits shall be reported to the manager of the facility.

**IV. RECORDKEEPING REQUIREMENTS.****# 012 [25 Pa. Code §127.441]****Operating permit terms and conditions.**

(a) The permittee shall maintain a logbook of the facility inspections performed. The logbook shall include the name of the company representative performing the inspection, the date and time of inspections, any instances of exceedances of visible emissions limitations, visible fugitive emissions limitations and malodorous air emissions limitations, and the name of the manager informed if a potential exceedance is observed. The permittee shall also record any and all corrective action(s) taken to abate each recorded deviation to prevent future occurrences.

(b) These records shall be retained for a minimum of five years and shall be made available to the Department upon request.

**# 013 [25 Pa. Code §127.441]****Operating permit terms and conditions.**

(a) The permittee shall keep records of tests or fuel certification reports of the percent sulfur by weight for each delivery of the #2 and lighter oil delivered to the facility,

OR

The permittee shall keep records of fuel certification reports obtained yearly from the #2 and lighter oil supplier stating that the sulfur percentage for each shipment of fuel delivered to the facility during the year shall not exceed 0.0015 % sulfur by weight.

(b) These records shall be retained for a minimum of five years and shall be made available to the Department upon request.

**# 014 [25 Pa. Code §135.5]****Recordkeeping**

The permittee shall maintain and make available upon request by the Department records including computerized records that may be necessary to comply with Sections 135.3 and 135.21 (relating to reporting; and emission statements). These may include records of production, fuel usage, maintenance of production or pollution control equipment or other information determined by the Department to be necessary for identification and quantification of potential and actual air contaminant emissions.

**V. REPORTING REQUIREMENTS.****# 015 [25 Pa. Code §127.441]****Operating permit terms and conditions.**

(a) The permittee shall report malfunctions, emergencies or incidents of excess emissions to the Department. A malfunction is any sudden, infrequent, and not reasonably preventable failure of air pollution control equipment, process

**SECTION C. Site Level Requirements**

equipment, or a process to operate in a normal or usual manner. An emergency is any situation arising from sudden and reasonably unforeseeable events beyond the control of the owner or operator of a facility which requires immediate corrective action to restore normal operation and which causes the emission source to exceed emissions, due to unavoidable increases in emissions attributable to the situation. An emergency shall not include situations caused by improperly designed equipment, lack of preventive maintenance, careless or improper operation, or operator error.

(b) When the malfunction, emergency or incident of excess emissions poses an imminent danger to the public health, safety, welfare, or environment, it shall be reported to the Department and the County Emergency Management Agency by telephone within one (1) hour after the discovery of the malfunction, emergency or incident of excess emissions. The owner or operator shall submit a written or emailed report of instances of such malfunctions, emergencies or incidents of excess emissions to the Department within three (3) business days of the telephone report.

(c) The report shall describe the following:

1. name, permit or authorization number, and location of the facility,
2. nature and cause of the malfunction, emergency or incident,
3. date and time when the malfunction, emergency or incident was first observed,
4. expected duration of excess emissions,
5. estimated rate of emissions,
6. corrective actions or preventative measures taken.

(d) Any malfunction, emergency or incident of excess emissions that is not subject to the notice requirements of paragraph (b) of this condition shall be reported to the Department by telephone within 24 hours (or by 4:00 PM of the next business day, whichever is later) of discovery and in writing or by e-mail within five (5) business days of discovery. The report shall contain the same information required by paragraph (c), and any permit specific malfunction reporting requirements.

(e) During an emergency an owner or operator may continue to operate the source at their discretion provided they submit justification for continued operation of a source during the emergency and follow all the notification and reporting requirements in accordance with paragraphs (b)-(d), as applicable, including any permit specific malfunction reporting requirements.

(f) Reports regarding malfunctions, emergencies or incidents of excess emissions shall be submitted to the appropriate DEP Regional Office Air Program Manager.

(g) Any emissions resulted from malfunction or emergency are to be reported in the annual emissions inventory report, if the annual emissions inventory report is required by permit or authorization.

**# 016 [25 Pa. Code §135.3]****Reporting**

(a) The permittee shall submit by March 1 of each year an Annual Air Information Management Systems (AIMS) Emissions report for the preceding calendar year. The report shall include information for all previously reported sources, new sources which were first operated during the preceding calendar year and sources modified during the same period which were not previously reported.

(b) The permittee may request an extension of time from the Department for the filing of an Annual Air Information Management Systems (AIMS) Emissions report, and the Department may grant the extension for reasonable cause.

**VI. WORK PRACTICE REQUIREMENTS.****# 017 [25 Pa. Code §123.1]****Prohibition of certain fugitive emissions**

For any source specified in 25 Pa. Code Section 123.1 subsection(s) (a)(1)-(7) or (a)(9), the permittee shall take all reasonable actions to prevent particulate matter from becoming airborne. These actions shall include, but not be limited to, the following:

- (1) Use, where possible, of water or chemicals for control of dust in the demolition of buildings or structures, construction

**SECTION C. Site Level Requirements**

operations, the grading of roads or the clearing of land.

(2) Application of asphalt, oil, or suitable chemicals on dirt roads, material stockpiles and other surfaces which may give rise to airborne dusts.

(3) Paving and maintenance of roadways.

(4) Prompt removal of earth or other material from paved streets onto which earth or other material has been transported by trucking or earth moving equipment, erosion by water, or other means.

**VII. ADDITIONAL REQUIREMENTS.**

**# 018 [25 Pa. Code §121.7]**

**Prohibition of air pollution.**

No person may permit air pollution as that term is defined in the act (The Air Pollution Control Act (35 P.S. Sections 4001-4015)).

**# 019 [25 Pa. Code §123.31]**

**Limitations**

No person may permit the emission into the outdoor atmosphere of any malodorous air contaminants from any source in a manner that the malodors are detectable outside the property of the person on whose land the source is being operated.

**# 020 [25 Pa. Code §127.441]**

**Operating permit terms and conditions.**

This equipment at the facility shall comply with all applicable air quality regulations specified in Pa. Code Chapters 121 - 145 at all times.

**# 021 [25 Pa. Code §129.14]**

**Open burning operations**

No person may permit the open burning of material at this facility unless in accordance with 25 Pa. Code Section 129.14.

**VIII. COMPLIANCE CERTIFICATION.**

No additional compliance certifications exist except as provided in other sections of this permit including Section B (relating to State Only General Requirements).

**IX. COMPLIANCE SCHEDULE.**

No compliance milestones exist.

**SECTION D. Source Level Requirements**

Source ID: 031

Source Name: 2 BOILERS (BOILER B101 &amp; WAREHOUSE BOILER)

Source Capacity/Throughput:

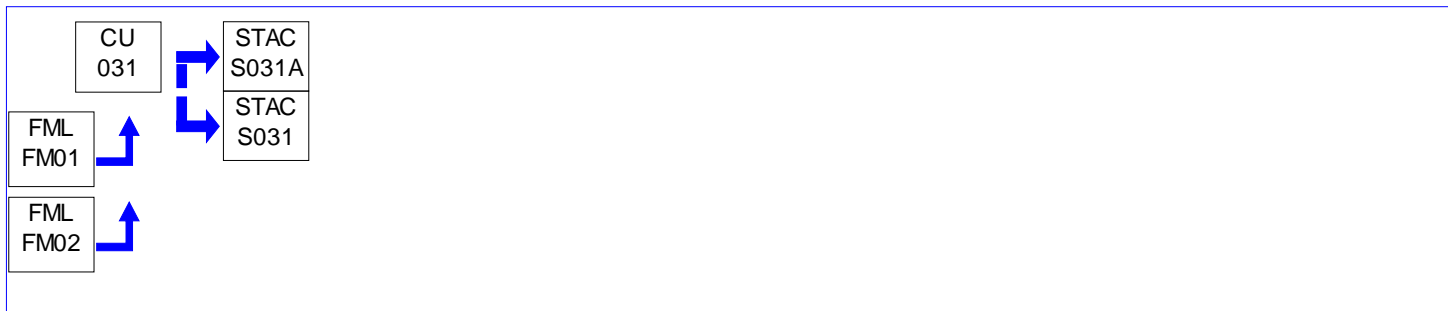
**I. RESTRICTIONS.****Emission Restriction(s).****# 001 [25 Pa. Code §123.22]****Combustion units**

[Compliance with the requirement specified in this streamlined permit condition assures compliance with the provision in 40 CFR Section 52.2020(c).]

No person may permit the emission into the outdoor atmosphere of sulfur oxides, expressed as SO<sub>2</sub>, from either boiler of Source ID. 031 in excess of the rate of 4 pounds per million Btu of heat input over any 1-hour period in accordance with 25 Pa. Code Section 123.22(a)(1).

**Fuel Restriction(s).****# 002 [25 Pa. Code §127.441]****Operating permit terms and conditions.**

[Additional authority for this permit condition is derived from 25 Pa. Code Section 123.22(a)(2)]

Each boiler of Source ID. 031 is to be fired only on #2 or lighter fuel oil. The sulfur content of the #2 and lighter fuel oil fired by Source ID. 031 shall not, at any time, exceed 0.0015% by weight.

**II. TESTING REQUIREMENTS.**

No additional testing requirements exist except as provided in other sections of this permit including Section B (State Only General Requirements).

**III. MONITORING REQUIREMENTS.**

No additional monitoring requirements exist except as provided in other sections of this permit including Section B (State Only General Requirements).

**IV. RECORDKEEPING REQUIREMENTS.****# 003 [40 CFR Part 63 NESHAPS for Source Categories §40 CFR 63.11225]****SUBPART JJJJJJ - National Emission Standards for Hazardous Air Pollutants for Industrial, Commercial, and Institutional Boilers Area Sources****What are my notification, reporting, and recordkeeping requirements?**

The permittee shall comply with the applicable notification, reporting, and recordkeeping requirements in 40 CFR Sections 63.11225(a), (b), (c), and (d).

**SECTION D. Source Level Requirements****V. REPORTING REQUIREMENTS.****# 004 [40 CFR Part 63 NESHAPS for Source Categories §40 CFR 63.11225]****SUBPART JJJJJJ - National Emission Standards for Hazardous Air Pollutants for Industrial, Commercial, and Institutional Boilers Area Sources****What are my notification, reporting, and recordkeeping requirements?**

The permittee shall comply with the applicable notification, reporting, and recordkeeping requirements in 40 CFR Sections 63.11225(a), (b), (c), and (d).

**# 005 [40 CFR Part 63 NESHAPS for Source Categories §40 CFR 63.13]****Subpart A--General Provisions****Addresses of State air pollution control agencies and EPA Regional Offices.**

The submission of all requests, reports, applications, submittals and other communications required by 40 CFR Part 63 Subpart JJJJJJ, Sections 63.11193 through 63.11237 shall be submitted to both the U. S. Environmental Protection Agency and the Department. The Environmental Protection Agency copies may be sent to:

R3\_Air\_Apps\_and\_Notices@epa.gov

And

United States Environmental Protection Agency  
Region III, Air and Radiation Division  
Permits Branch (3AD10)  
Four Penn Center  
1600 John F. Kennedy Boulevard  
Philadelphia, Pennsylvania 19103-2852

And

The Pennsylvania Department of Environmental Protection  
Air Quality Program Manager  
208 W. Third Street, Suite 101  
Williamsport, PA 17701-6448

**VI. WORK PRACTICE REQUIREMENTS.**

No additional work practice requirements exist except as provided in other sections of this permit including Section B (State Only General Requirements).

**VII. ADDITIONAL REQUIREMENTS.****# 006 [25 Pa. Code §127.441]****Operating permit terms and conditions.**

Source ID. 031 is a group of two (2) #2 and lighter fuel oil-fired boilers, described as follows:

(1) one (1) Superior Boiler model JB2-10 boiler with a rated capacity of 1.67 MMBtu per hour

(2) one (1) Bryan Flex Tube model CL-120-WT boiler with a rated capacity of 1.2 MMBTU per hour (also designated as warehouse boiler)

**# 007 [40 CFR Part 63 NESHAPS for Source Categories §40 CFR 63.11193]****SUBPART JJJJJJ - National Emission Standards for Hazardous Air Pollutants for Industrial, Commercial, and Institutional Boilers Area Sources****Am I subject to this subpart?**

Source ID 031 is subject to the requirements of 40 CFR Part 63 Subpart JJJJJJ, Sections 63.11193 through 63.11237. The permittee shall comply with all applicable requirements specified in 40 CFR Part 63 Subpart JJJJJJ, Sections 63.11193 through 63.11237.

**SECTION D. Source Level Requirements****# 008 [40 CFR Part 63 NESHAPS for Source Categories §40 CFR 63.11201]****SUBPART JJJJJJ - National Emission Standards for Hazardous Air Pollutants for Industrial, Commercial, and Institutional Boilers Area Sources****What standards must I meet?**

The permittee shall comply with the applicable standards in 40 CFR Section 63.11201(b).

**# 009 [40 CFR Part 63 NESHAPS for Source Categories §40 CFR 63.11205]****SUBPART JJJJJJ - National Emission Standards for Hazardous Air Pollutants for Industrial, Commercial, and Institutional Boilers Area Sources****What are my general requirements for complying with this subpart?**

The permittee shall comply with the applicable general requirements in 40 CFR Section 63.11205(a).

**# 010 [40 CFR Part 63 NESHAPS for Source Categories §40 CFR 63.11210]****SUBPART JJJJJJ - National Emission Standards for Hazardous Air Pollutants for Industrial, Commercial, and Institutional Boilers Area Sources****What are my initial compliance requirements and by what date must I conduct them?**

The permittee shall comply with the applicable initial compliance requirements in 40 CFR Section 63.11210(c).

**# 011 [40 CFR Part 63 NESHAPS for Source Categories §40 CFR 63.11223]****SUBPART JJJJJJ - National Emission Standards for Hazardous Air Pollutants for Industrial, Commercial, and Institutional Boilers Area Sources****How do I demonstrate continuous compliance with the work practice and management practice standards?**

The permittee shall comply with the applicable continuous compliance requirements in 40 CFR Sections 63.11223(a) and (e).

**# 012 [40 CFR Part 63 NESHAPS for Source Categories §40 CFR 63.11235]****SUBPART JJJJJJ - National Emission Standards for Hazardous Air Pollutants for Industrial, Commercial, and Institutional Boilers Area Sources****What parts of the General Provisions apply to me?**

The permittee shall comply with the the applicable general requirements in 40 CFR Section 63.11235.

**SECTION D. Source Level Requirements**

Source ID: 034

Source Name: SAMPLE SINTERING FURNACE

Source Capacity/Throughput:

**I. RESTRICTIONS.****Emission Restriction(s).**

# 001 [25 Pa. Code §123.13]

**Processes**

No person may permit the emission into the outdoor atmosphere of particulate matter from Source ID 034 in a manner that the concentration of particulate matter in the effluent gas exceeds 0.04 grain per dry standard cubic foot.

# 002 [25 Pa. Code §123.21]

**General**

No person may permit the emission into the outdoor atmosphere of sulfur oxides from Source ID 034 in a manner that the concentration of the sulfur oxides, expressed as SO<sub>2</sub>, in the effluent gas exceeds 500 parts per million, by volume, dry basis.

**Fuel Restriction(s).**

# 003 [25 Pa. Code §127.441]

**Operating permit terms and conditions.**

Source ID. 034 shall be fired only on hydrogen or propane.

**II. TESTING REQUIREMENTS.**

No additional testing requirements exist except as provided in other sections of this permit including Section B (State Only General Requirements).

**III. MONITORING REQUIREMENTS.**

No additional monitoring requirements exist except as provided in other sections of this permit including Section B (State Only General Requirements).

**IV. RECORDKEEPING REQUIREMENTS.**

No additional record keeping requirements exist except as provided in other sections of this permit including Section B (State Only General Requirements).

**V. REPORTING REQUIREMENTS.**

No additional reporting requirements exist except as provided in other sections of this permit including Section B (State Only General Requirements).



**SECTION D. Source Level Requirements****VI. WORK PRACTICE REQUIREMENTS.**

No additional work practice requirements exist except as provided in other sections of this permit including Section B (State Only General Requirements).

**VII. ADDITIONAL REQUIREMENTS.**

**# 004 [25 Pa. Code §127.441]**

**Operating permit terms and conditions.**

Source ID. 034 is a C.I. Hayes model BA2KTMAtmospheric 24 kW electrical sintering furnace for product samples with a hydrogen/propane-fired safety flare having a maximum heat input of 0.06 MMBtu/hr.

**SECTION D. Source Level Requirements**

Source ID: 035

Source Name: 25 SPACE HEATERS

Source Capacity/Throughput:

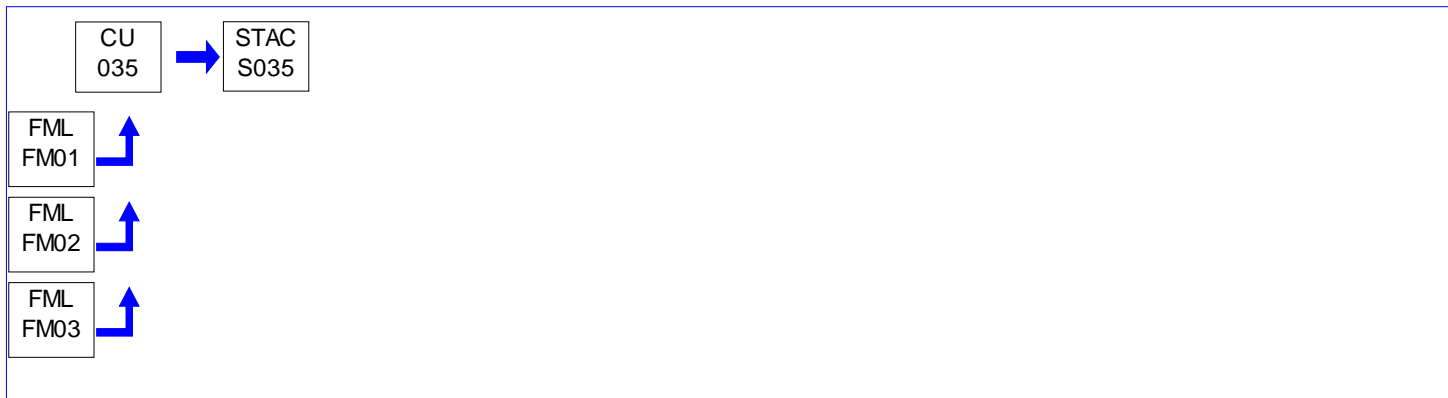
**I. RESTRICTIONS.****Emission Restriction(s).**

# 001 [25 Pa. Code §123.22]

**Combustion units**

[Compliance with the requirement specified in this streamlined permit condition assures compliance with the provision in 40 CFR Section 52.2020(c).]

No person may permit the emission into the outdoor atmosphere of sulfur oxides, expressed as SO<sub>2</sub>, from any space heater of Source ID. 035 in excess of the rate of 4 pounds per million Btu of heat input over any 1-hour period in accordance with 25 Pa. Code Section 123.22(a)(1).

**Fuel Restriction(s).**

# 002 [25 Pa. Code §127.441]

**Operating permit terms and conditions.**

[Additional authority for this permit condition is derived from 25 Pa. Code Section 123.22(a)(2)]

Each space heater of Source ID. 035 is to be fired only on #2 or lighter fuel oil. The sulfur content of the #2 and lighter fuel oil fired by each space heater of Source ID. 035 shall not, at any time, exceed 0.0015% by weight.

**II. TESTING REQUIREMENTS.**

No additional testing requirements exist except as provided in other sections of this permit including Section B (State Only General Requirements).

**III. MONITORING REQUIREMENTS.**

No additional monitoring requirements exist except as provided in other sections of this permit including Section B (State Only General Requirements).

**IV. RECORDKEEPING REQUIREMENTS.**

No additional record keeping requirements exist except as provided in other sections of this permit including Section B (State Only General Requirements).

**SECTION D. Source Level Requirements****V. REPORTING REQUIREMENTS.**

No additional reporting requirements exist except as provided in other sections of this permit including Section B (State Only General Requirements).

**VI. WORK PRACTICE REQUIREMENTS.**

No additional work practice requirements exist except as provided in other sections of this permit including Section B (State Only General Requirements).

**VII. ADDITIONAL REQUIREMENTS.**

**# 003 [25 Pa. Code §127.441]**

**Operating permit terms and conditions.**

Source ID. 035 consists of the following twenty-five (25) #2 and lighter fuel oil-fired space heaters:

# Units	Manufacturer	Model Number	Capacity
1	Jackson & Church	JO-35-202-MZ-MB	423,000 BTU/hr
4	Rheem Manuf. Co.	LOTDM-50	600,000 BTU/hr
2	Rheem Manuf. Co.	LOTDM-25	317,250 BTU/hr
2	Rheem Manuf. Co.	LOTDM-20	176,250 BTU/hr
2	Rheem Manuf. Co.	LOTDM-100	1,262,000 BTU/hr
2	Rheem Manuf. Co.	LOTDM-20	126,900 BTU/hr
1	Rheem Manuf. Co.	LOTDM-20	169,200 BTU/hr
1	Rheem Manuf. Co.	LOTDM-20 H1	126,900 BTU/hr
5	Associated with Source ID. P109		119,000 BTU/hr
2	Associated with Source ID. P109		175,000 BTU/hr
2	Associated with AncorBond 5		10,500 Btu/hr
1	Associated with Source ID P102		1,250,000 Btu/hr

**SECTION D. Source Level Requirements**

Source ID: P101

Source Name: METL POWD BLEND &amp; BOND OPERATIONS

Source Capacity/Throughput:

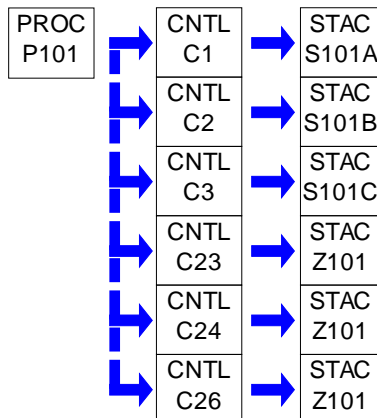
**I. RESTRICTIONS.****Emission Restriction(s).****# 001 [25 Pa. Code §127.441]****Operating permit terms and conditions.**

[Compliance with this permit condition also assures compliance with 25 Pa. Code Section 123.13]

The PM10 and PM2.5 emissions exhausted from each collector shall not exceed 0.01 gr/dscf.

**Throughput Restriction(s).****# 002 [25 Pa. Code §127.441]****Operating permit terms and conditions.**

The permittee shall limit the number of batches processed through the VT-4200 mixer of Source ID P101 to 17,520 in any 12 consecutive month period.

**# 003 [25 Pa. Code §127.441]****Operating permit terms and conditions.**

The permittee shall limit the number of batches processed through the proprietary acid process of Source ID P101 to 4,000 in any 12 consecutive month period.

**# 004 [25 Pa. Code §127.441]****Operating permit terms and conditions.**

The maximum throughput of material through the 800-gallon binder/lube mix tank shall not exceed 500,000 gallons in any 12 consecutive month period.

**# 005 [25 Pa. Code §127.441]****Operating permit terms and conditions.**

The permittee shall limit the number of hopper loads processed through the bonding glue hopper to 2,080 in any 12 consecutive month period.

**II. TESTING REQUIREMENTS.**

No additional testing requirements exist except as provided in other sections of this permit including Section B (State Only General Requirements).

**SECTION D. Source Level Requirements****III. MONITORING REQUIREMENTS.****# 006 [25 Pa. Code §127.441]****Operating permit terms and conditions.**

The permittee shall equip each cartridge collector with instrumentation to accurately and continuously measure the pressure drop across the collector to verify proper operation of the collector and the need for cartridge replacement.

**# 007 [25 Pa. Code §127.441]****Operating permit terms and conditions.**

The 800-gallon binder/lube mix tank shall be equipped with a pressure gauge capable of continuously measuring the pressure in the tank.

**# 008 [25 Pa. Code §127.441]****Operating permit terms and conditions.**

All condensers (Control Device IDs C24 and C26) associated with Source ID P101 shall be equipped with instrumentation to accurately and continuously measure the coolant temperatures in the condensers.

**IV. RECORDKEEPING REQUIREMENTS.****# 009 [25 Pa. Code §127.441]****Operating permit terms and conditions.**

(a) The permittee shall keep records of calculations to verify compliance with the particulate matter emission limitation for each stack of Source ID. P101.

(b) All records generated pursuant to this condition shall be generated and complete no later than 15 calendar days after the end of each month (for example, the record covering the 12-consecutive month period beginning at the start of August 2023 through the end of July 2024 shall be generated and completed by August 15, 2024).

(c) All records generated pursuant to this condition shall be retained for a minimum of five years and shall be made available to the Department upon request.

**# 010 [25 Pa. Code §127.441]****Operating permit terms and conditions.**

(a) The permittee shall keep records of the number of batches processed each month through the VT-4200 mixer.

(b) All records generated pursuant to this condition shall be generated and complete no later than 15 calendar days after the end of each month (for example, the record covering the 12-consecutive month period beginning at the start of August 2023 through the end of July 2024 shall be generated and completed by August 15, 2024).

(c) All records generated pursuant to this condition shall be retained for a minimum of five years and shall be made available to the Department upon request.

**# 011 [25 Pa. Code §127.441]****Operating permit terms and conditions.**

(a) The permittee shall keep records of the number of batches run through the proprietary acid process each month.

(b) All records generated pursuant to this condition shall be generated and complete no later than 15 calendar days after the end of each month (for example, the record covering the 12-consecutive month period beginning at the start of August 2023 through the end of July 2024 shall be generated and completed by August 15, 2024).

(c) All records generated pursuant to this condition shall be retained for a minimum of five years and shall be made available to the Department upon request.

**# 012 [25 Pa. Code §127.441]****Operating permit terms and conditions.**

The permittee shall keep comprehensive and accurate logbooks of the pressure drop across each cartridge collector at least once each week while the collector is in operation. The logbook shall include the observer's initials, date of observation, time of observation, and pressure drop as well as the manufacturer's recommended acceptable pressure drop

**SECTION D. Source Level Requirements**

range. The pressure drop logs shall be retained for a minimum of five years and shall be made available to the Department upon request.

**# 013 [25 Pa. Code §127.441]****Operating permit terms and conditions.**

- (a) The permittee shall keep records of the amount of material used in the 800-gallon binder/lube mix tank each month and shall verify compliance with the throughput limitation in any 12 consecutive month period.
- (b) All records generated pursuant to this condition shall be generated and complete no later than 15 calendar days after the end of each month (for example, the record covering the 12-consecutive month period beginning at the start of August 2023 through the end of July 2024 shall be generated and completed by August 15, 2024).
- (c) All records generated pursuant to this condition shall be retained for a minimum of five years and shall be made available to the Department upon request.

**# 014 [25 Pa. Code §127.441]****Operating permit terms and conditions.**

- (a) The permittee shall keep records of the temperature(s) of the coolant used in all condensers associated with the metal powder bonding operation of Source ID P101. For condensers CO-102 and CO-103 records shall be kept of the inlet and outlet coolant temperatures.
- (b) The temperature(s) shall be recorded, at a minimum, once per day during process operations that vent to the condenser being recorded.
- (c) These records shall be retained for a minimum of five (5) years and made available to the Department upon request.

**# 015 [25 Pa. Code §127.441]****Operating permit terms and conditions.**

- (a) The permittee shall keep records of the number of bonding glue hopper loads each month in the bonding glue hopper and shall verify compliance with the load limitation in any 12 consecutive month period.
- (b) All records generated pursuant to this condition shall be generated and complete no later than 15 calendar days after the end of each month (for example, the record covering the 12-consecutive month period beginning at the start of August 2023 through the end of July 2024 shall be generated and completed by August 15, 2024).
- (c) All records generated pursuant to this condition shall be retained for a minimum of five years and shall be made available to the Department upon request.

**# 016 [25 Pa. Code §127.441]****Operating permit terms and conditions.**

- (a) The permittee shall maintain a record of the number of batches processed through the powdered metals bonding operation of Source ID. P101.
- (b) All records generated pursuant to this condition shall be generated and complete no later than 15 calendar days after the end of each month (for example, the record covering the 12-consecutive month period beginning at the start of August 2023 through the end of July 2024 shall be generated and completed by August 15, 2024).
- (c) All records generated pursuant to this condition shall be retained for a minimum of five years and shall be made available to the Department upon request.

**SECTION D. Source Level Requirements****V. REPORTING REQUIREMENTS.**

No additional reporting requirements exist except as provided in other sections of this permit including Section B (State Only General Requirements).

**VI. WORK PRACTICE REQUIREMENTS.**

**# 017 [25 Pa. Code §127.441]**

**Operating permit terms and conditions.**

The inlet coolant temperature to CO-102 and CO-103 (Control Device ID C24) shall not exceed 32 degrees Farenheit.

**# 018 [25 Pa. Code §127.441]**

**Operating permit terms and conditions.**

The permittee shall only use acetone as the solvent used in the VT-4200 mixer of Source ID P101.

**# 019 [25 Pa. Code §127.441]**

**Operating permit terms and conditions.**

The permittee shall not unload any material in the hand-add station which contains lead or hazardous air pollutants as described in the Request for Determination of Requirement for Plan Approval (RFD) approved by the Department on October 16, 2013.

**# 020 [25 Pa. Code §127.441]**

**Operating permit terms and conditions.**

The permittee shall keep on hand a sufficient quantity of spare cartridges in order to be able to immediately replace any cartridges requiring replacement due to deterioration resulting from routine operation cartridge collectors.

**# 021 [25 Pa. Code §127.441]**

**Operating permit terms and conditions.**

The 800-gallon binder/lube mix tank shall be equipped with a pressure relief valve that shall be set to release at no less than 3 psig of pressure and shall be vented to condenser CO-104 (Control Device ID C26).

**# 022 [25 Pa. Code §127.441]**

**Operating permit terms and conditions.**

The 800-gallon binder/lube mix tank shall be blanketed with nitrogen.

**VII. ADDITIONAL REQUIREMENTS.**

**# 023 [25 Pa. Code §127.441]**

**Operating permit terms and conditions.**

Source ID P101 is a metal powder blending and bonding operation. Source ID P101 consists of the following:

- (1) Three (3) major flexbag unloading stations
- (2) One (1) minor additive system consisting of a fill station, a dispensing station and a hand-add station.
- (3) a metal powder blending operation consisting of 3 receiving bins, one mass weigh hopper, bonding and blending dumper, and one blending port screener.
- (4) a metal powder bonding operation.

The air contaminant emissions from the ventilation process of Source ID P101 and the Hand Add Request for Determination [#4373] are handled by dust/cartridge collectors C1, C2 and C3. The cartridge collectors are Donaldson model DFO UW with ultra-web media, authorized via Request for Determination on September 27, 2016.

**SECTION D. Source Level Requirements****# 024 [25 Pa. Code §127.441]****Operating permit terms and conditions.**

The permittee shall operate the cartridge collectors in accordance with the manufacturer's recommendations and good air pollution control practices.

**# 025 [25 Pa. Code §127.441]****Operating permit terms and conditions.**

[Additional authority for this permit condition is derived from 25 Pa. Code Sections 127.1 and 127.12.]

Pursuant to the best available technology provisions of 25 Pa. Code Sections 127.1 and 127.12, the coolant used in all condensers associated with the metal powder bonding operation of Source ID. P101 shall be maintained at a temperature of zero (0) degrees C or lower.



**SECTION D. Source Level Requirements**

Source ID: P106

Source Name: METL POWD MANUFACT OPERATION

Source Capacity/Throughput:

**I. RESTRICTIONS.****Emission Restriction(s).****# 001 [25 Pa. Code §123.22]****Combustion units**

[Compliance with the requirement specified in this streamlined permit condition assures compliance with the provision in 40 CFR Section 52.2020(c).]

No person may permit the emission into the outdoor atmosphere of sulfur oxides, expressed as SO<sub>2</sub>, from the Lattner #20HRT boiler of Source ID. P106 in excess of the rate of 4 pounds per million Btu of heat input over any 1-hour period in accordance with 25 Pa. Code Section 123.22(a)(1).

**# 002 [25 Pa. Code §127.441]****Operating permit terms and conditions.**

[Compliance with this permit condition also assures compliance with 25 Pa. Code Section 123.13]

The PM<sub>10</sub> and PM<sub>2.5</sub> emissions exhausted from cartridge collector C4 shall not exceed 0.01 gr/dscf.

**Fuel Restriction(s).****# 003 [25 Pa. Code §127.441]****Operating permit terms and conditions.**

[Additional authority for this permit condition is derived from 25 Pa. Code Section 123.22(a)(2)]

The boiler incorporated in Source ID. P106 is to be fired only on #2 or lighter fuel oil. The sulfur content of the #2 and lighter fuel oil fired by the boiler shall not, at any time, exceed 0.0015% by weight.

**II. TESTING REQUIREMENTS.**

No additional testing requirements exist except as provided in other sections of this permit including Section B (State Only General Requirements).

**III. MONITORING REQUIREMENTS.****# 004 [25 Pa. Code §127.441]****Operating permit terms and conditions.**

The permittee shall equip cartridge collector C4 with instrumentation to accurately and continuously measure the pressure drop across the collector to verify proper operation of the collector and the need for cartridge replacement.

**IV. RECORDKEEPING REQUIREMENTS.****# 005 [25 Pa. Code §127.441]****Operating permit terms and conditions.**

The permittee shall keep comprehensive and accurate logbooks of the pressure drop across cartridge collector C4 at least once each week while the collector is in operation. The logbook shall include the observer's initials, date of observation, time of observation, and pressure drop as well as the manufacturer's recommended acceptable pressure drop range. The pressure drop logs shall be retained for a minimum of five years and shall be made available to the Department upon request.

**SECTION D. Source Level Requirements****# 006 [25 Pa. Code §127.441]****Operating permit terms and conditions.**

(a) The permittee shall keep records of calculations to verify compliance with the particulate matter emission limitation for each cartridge collector of Source ID. P106.

(b) All records generated pursuant to this condition shall be generated and complete no later than 15 calendar days after the end of each month (for example, the record covering the 12-consecutive month period beginning at the start of August 2023 through the end of July 2024 shall be generated and completed by August 15, 2024).

(c) All records generated pursuant to this condition shall be retained for a minimum of five years and shall be made available to the Department upon request.

**V. REPORTING REQUIREMENTS.**

No additional reporting requirements exist except as provided in other sections of this permit including Section B (State Only General Requirements).

**VI. WORK PRACTICE REQUIREMENTS.****# 007 [25 Pa. Code §127.441]****Operating permit terms and conditions.**

The permittee shall keep on hand a sufficient quantity of spare cartridges in order to be able to immediately replace any cartridges requiring replacement due to deterioration resulting from routine operation of cartridge collector C4.

**# 008 [25 Pa. Code §127.441]****Operating permit terms and conditions.**

Source ID P106 shall not run simultaneously with either the blending operation or bonding operation of Source ID P121.

**VII. ADDITIONAL REQUIREMENTS.****# 009 [25 Pa. Code §127.441]****Operating permit terms and conditions.**

The permittee shall operate the cartridge collector C4 in accordance with the manufacturer's recommendations and good air pollution control practices.

**# 010 [25 Pa. Code §127.441]****Operating permit terms and conditions.**

(a) Source ID. P106 is a powdered metals manufacturing operation consisting of:

- (1) one (1) heated powdered metals mixer
- (2) six (6) additive bins
- (3) one (1) bulk pack dumper
- (4) three (3) iron bins
- (5) one (1) bucket elevator
- (6) one (1) metal bin
- (7) one (1) cold bin
- (8) one (1) heated weigh hopper
- (9) one (1) dosage hopper
- (10) one (1) "add" bins
- (11) one (1) screener
- (12) one (1) loadout station
- (13) one (1) electric screw conveyor
- (14) product sample blending and bonding operations as described in the Request for Determination of Requirement for Plan Approval approved on June 8, 2006.

**SECTION D. Source Level Requirements**

(b) The air contaminant emissions from the heated powdered metals mixer of Source ID P106 shall be controlled by dust collector C4, a Donaldson model DFO UW ultra-web media cartridge collector, authorized via Request for Determination on September 27, 2016.

(15) One (1) 16 horsepower Lattner #20HRT #2 fuel oil-fired boiler.

**# 011 [25 Pa. Code §127.441]**

**Operating permit terms and conditions.**

The product sample blending and bonding operations of Source ID P106 shall not run simultaneously with the other operations of Source ID P106.

**SECTION D. Source Level Requirements**

Source ID: P109

Source Name: SPECIALTY BLENDED METALS PROCESS

Source Capacity/Throughput:

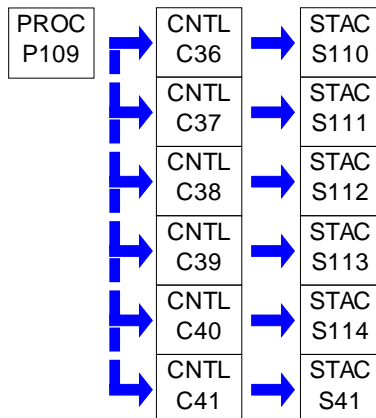
**I. RESTRICTIONS.****Emission Restriction(s).**

**# 001 [25 Pa. Code §123.13]**  
**Processes**

No person may permit the emission into the outdoor atmosphere of particulate matter from the exhaust of each stack of Source ID. P109 in excess of 0.04 grains per dry standard cubic foot.

**# 002 [25 Pa. Code §127.441]**  
**Operating permit terms and conditions.**

[Additional authority for this permit condition is derived from the Request for Determination dated August 20, 2015]

The total PM10 and PM2.5 emissions from the F 417 product process shall not exceed 0.30 tons and 0.20 tons, respectively, in any 12 consecutive month period.

**Throughput Restriction(s).**

**# 003 [25 Pa. Code §127.441]**  
**Operating permit terms and conditions.**

[Additional authority for this permit condition is derived from the Request for Determination dated August 20, 2015]

The maximum throughput of F 417 material processed shall not exceed 20,000,000 pounds in any 12 consecutive month period.

**II. TESTING REQUIREMENTS.**

No additional testing requirements exist except as provided in other sections of this permit including Section B (State Only General Requirements).

**III. MONITORING REQUIREMENTS.**

No additional monitoring requirements exist except as provided in other sections of this permit including Section B (State Only General Requirements).

**SECTION D. Source Level Requirements****IV. RECORDKEEPING REQUIREMENTS.****# 004 [25 Pa. Code §127.441]****Operating permit terms and conditions.**

(a) The permittee shall keep records of calculations to verify compliance with each particulate matter emission limitation for Source ID. P109.

(b) All records generated pursuant to this condition shall be generated and complete no later than 15 calendar days after the end of each month (for example, the record covering the 12-consecutive month period beginning at the start of August 2023 through the end of July 2024 shall be generated and completed by August 15, 2024).

(c) All records generated pursuant to this condition shall be retained for a minimum of five years and shall be made available to the Department upon request.

**# 005 [25 Pa. Code §127.441]****Operating permit terms and conditions.**

[Additional authority for this permit condition is derived from the Request for Determination dated August 20, 2015]

(a) The permittee shall keep a comprehensive and accurate logbook of the pressure drop across the cartridge collector at least once per week while the F 417 product process is in operation. In addition to the pressure drop, the logbook shall also include the date the reading was observed and the initials of the observer.

(b) The logbook shall be retained on file for a minimum of five (5) years and made available to the Department upon request.

**# 006 [25 Pa. Code §127.441]****Operating permit terms and conditions.**

[Additional authority for this permit condition is derived from the Request for Determination dated August 20, 2015]

(a) The permittee shall keep comprehensive and accurate records documenting the number of pounds of F 417 product is processed each month to demonstrate compliance with the throughput restriction.

(b) All records generated pursuant to this condition shall be generated and complete no later than 15 calendar days after the end of each month (for example, the record covering the 12-consecutive month period beginning at the start of August 2023 through the end of July 2024 shall be generated and completed by August 15, 2024).

(c) All records generated pursuant to this condition shall be retained for a minimum of five years and shall be made available to the Department upon request.

**V. REPORTING REQUIREMENTS.**

No additional reporting requirements exist except as provided in other sections of this permit including Section B (State Only General Requirements).

**VI. WORK PRACTICE REQUIREMENTS.****# 007 [25 Pa. Code §127.441]****Operating permit terms and conditions.**

The permittee shall keep on hand a sufficient quantity of spare cartridges and fabric collector bags for the cartridge collectors and fabric collector associated with Source ID P109 in order to be able to immediately replace any cartridges or bags requiring replacement.

**# 008 [25 Pa. Code §127.441]****Operating permit terms and conditions.**

[Additional authority for this permit condition is derived from the Request for Determination dated August 20, 2015]

At no point in time shall the equipment in the F 417 process be operated without the simultaneous operation of the associated cartridge collector.

**SECTION D. Source Level Requirements****# 009 [25 Pa. Code §127.441]****Operating permit terms and conditions.**

[Additional authority for this permit condition is derived from the Request for Determination dated August 20, 2015]

The cartridge collector shall be equipped with operable instrumentation to monitor the differential pressure across the cartridge collector on a continuous basis.

**VII. ADDITIONAL REQUIREMENTS.****# 010 [25 Pa. Code §127.441]****Operating permit terms and conditions.**

No volatile organic compound-containing materials or hazardous air pollutant-containing materials shall be processed in Source ID. P109.

**# 011 [25 Pa. Code §127.441]****Operating permit terms and conditions.**

(a) Source ID P109 is a specialty blended metals process as described in the "Request for Determination of Requirement for Plan Approval" package submitted to the Department on June 9, 1999.

(1) Source ID P109 includes four carbon silos, an unloading hopper for carbon, an unloading hopper for base iron, a mixer and product bins (pack outs). The air contaminant emissions from each of the four carbon silos shall be controlled by four bin vent cartridge collectors (Control Device ID C38).

The air contaminant emissions from the unloading hopper for carbon shall be controlled by a Donaldson/Torit cartridge collector (Control Device ID C39).

The air contaminant emissions from the unloading hopper for base iron shall be controlled by Donaldson/Torit cartridge collector (Control Device ID C37).

The air contaminant emissions from the mixer shall be controlled by a bin vent fabric collector (Control Device ID C40).

The air contaminant emissions from the product bins shall be controlled by a Donaldson/Torit cartridge collector (Control Device ID C36).

(b) Source ID P109 consists of the F 417 product process that includes one 30 mesh screen and a disintegrator, approved via Request for Determination on August 20, 2015.

The air contaminant emissions from the F 417 product process shall be controlled by a MAC 2M2F8 pulse jet cartridge collector (Control Device ID C41).

**SECTION D. Source Level Requirements**

Source ID: P112

Source Name: AGM DELIVERY SYSTEM

Source Capacity/Throughput:

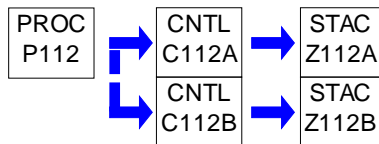
**I. RESTRICTIONS.****Throughput Restriction(s).****# 001 [25 Pa. Code §127.441]****Operating permit terms and conditions.**

The permittee shall not use the AGM delivery system for more than 2,424 unloading/loading events in any 12 consecutive month period.

**II. TESTING REQUIREMENTS.**

No additional testing requirements exist except as provided in other sections of this permit including Section B (State Only General Requirements).

**III. MONITORING REQUIREMENTS.**

No additional monitoring requirements exist except as provided in other sections of this permit including Section B (State Only General Requirements).

**IV. RECORDKEEPING REQUIREMENTS.****# 002 [25 Pa. Code §127.441]****Operating permit terms and conditions.**

(a) The permittee shall keep records of the number of unloading/loading events delivered by the AGM delivery system each month and shall verify compliance with the unloading/loading event limitation in any 12 consecutive month period.

(b) All records generated pursuant to this condition shall be generated and complete no later than 15 calendar days after the end of each month (for example, the record covering the 12-consecutive month period beginning at the start of August 2023 through the end of July 2024 shall be generated and completed by August 15, 2024).

(c) All records generated pursuant to this condition shall be retained for a minimum of five years and shall be made available to the Department upon request.

**V. REPORTING REQUIREMENTS.**

No additional reporting requirements exist except as provided in other sections of this permit including Section B (State Only General Requirements).

**VI. WORK PRACTICE REQUIREMENTS.****# 003 [25 Pa. Code §127.441]****Operating permit terms and conditions.**

The permittee shall keep on hand spare fabric collector bags and BUSCH filters in order to immediately replace any bags or filters requiring replacement.

**SECTION D. Source Level Requirements****VII. ADDITIONAL REQUIREMENTS.****# 004 [25 Pa. Code §127.441]****Operating permit terms and conditions.**

Source ID P112 is an AGM delivery system consisting of AGM material bags, a discharge hopper and a receiving hopper as described in the Request for Determination of Requirement for Plan Approval (RFD) approved by the Department on December 2, 2004 and revised RFD approved on July 26, 2006.

The air contaminant emissions from the discharge hopper (H-1) and AGM material bags shall be controlled by the AZO, Inc. pulse jet evacuation bag filter (F-1) and associated BUSCH vacuum filters (V-1) (Control Device ID C112A).

The air contaminant emissions from the receiving hopper (H-2) shall be controlled by the AZO, Inc. pulse jet fabric collector (B-1) and associated BUSCH vacuum filters (V-2) (Control Device ID C112B).

**# 005 [25 Pa. Code §127.441]****Operating permit terms and conditions.**

The air contaminant emissions from the AGM delivery system and associated filter controls (Control Device IDs C112A and C112B) shall be exhausted indoors and shall not have the potential to exhaust to the outdoor atmosphere.



**SECTION D. Source Level Requirements**

Source ID: P113

Source Name: DISTALOY SCREEN SYSTEM

Source Capacity/Throughput:

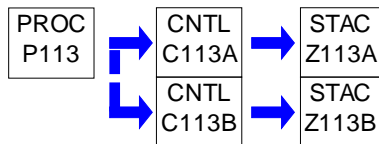
**I. RESTRICTIONS.**

No additional requirements exist except as provided in other sections of this permit including Section B (State Only General Requirements).

**II. TESTING REQUIREMENTS.**

No additional testing requirements exist except as provided in other sections of this permit including Section B (State Only General Requirements).

**III. MONITORING REQUIREMENTS.****# 001 [25 Pa. Code §127.441]****Operating permit terms and conditions.**

The differential pressure across Control Device IDs C113A and C113B shall be continuously measured using properly installed and operated instrumentation, which shall be used to monitor the proper operation of the control devices and the need for bag and/or HEPA filter replacement due to deterioration, tears, clogging, etc.

**IV. RECORDKEEPING REQUIREMENTS.****# 002 [25 Pa. Code §127.441]****Operating permit terms and conditions.**

The permittee shall keep records of the differential pressure across both Control Device IDs C113A and C113B at least once each week.

The records shall be retained for a minimum of five years and shall be made available to the Department upon request.

**V. REPORTING REQUIREMENTS.**

No additional reporting requirements exist except as provided in other sections of this permit including Section B (State Only General Requirements).

**VI. WORK PRACTICE REQUIREMENTS.****# 003 [25 Pa. Code §127.441]****Operating permit terms and conditions.**

The permittee shall keep on hand spare fabric collector bags and HEPA filters in order to immediately replace any bag or HEPA filter that is deteriorated, torn, clogged, etc.

**VII. ADDITIONAL REQUIREMENTS.****# 004 [25 Pa. Code §127.441]****Operating permit terms and conditions.**

Source ID P113 is a Distaloy screening system consisting of a dumper discharge hopper, a screener, an undersize weighup/ pack-out station and an oversize weigh-up/pack-out station as described in the Request for Determination of Requirement for Plan Approval approved on March 10, 2005.

The air contaminant emissions from the dumper discharge hopper and the screener shall be controlled by a reverse air jet

**SECTION D. Source Level Requirements**

type fabric collector followed by a HEPA filter (Control Device ID C113A).

The air contaminant emissions from the undersize and oversize weigh-up/pack-out stations shall be controlled by a reverse air jet type fabric collector followed by a HEPA filter (Control Device ID C113B).

**# 005 [25 Pa. Code §127.441]**

**Operating permit terms and conditions.**

The air contaminant emissions from the Distaloy screening system and associated fabric collectors and HEPA filters (Control Device IDs C113A and C113B) shall be exhausted indoors and shall not have the potential to exhaust to the outdoor atmosphere.

**SECTION D. Source Level Requirements**

Source ID: P121

Source Name: SAMPLE PRODUCTION PROCESS

Source Capacity/Throughput:

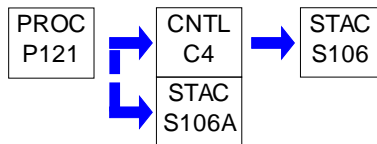
**I. RESTRICTIONS.****Emission Restriction(s).**

# 001 [25 Pa. Code §127.441]

**Operating permit terms and conditions.**

The acetone emissions from Source ID P121 shall not exceed eight (8) tons in any 12 consecutive month period.

**Throughput Restriction(s).**

# 002 [25 Pa. Code §127.441]

**Operating permit terms and conditions.**

The permittee shall not use more than 40 pounds of acetone per batch (calendar month average) in the bonding operation of Source ID P121.

**II. TESTING REQUIREMENTS.**

No additional testing requirements exist except as provided in other sections of this permit including Section B (State Only General Requirements).

**III. MONITORING REQUIREMENTS.**

# 003 [25 Pa. Code §127.441]

**Operating permit terms and conditions.**

The permittee shall equip the cartridge collector (Control Device ID C4) with instrumentation to accurately and continuously measure the pressure drop across the collector to verify proper operation of the collector.

**IV. RECORDKEEPING REQUIREMENTS.**

# 004 [25 Pa. Code §127.441]

**Operating permit terms and conditions.**

The permittee shall record the pressure across the cartridge collector (Control Device ID C4) associated with Source ID P121 at least once each week.

The records shall be retained for a minimum of five years and shall be made available to the Department upon request.

# 005 [25 Pa. Code §127.441]

**Operating permit terms and conditions.**

(a) The permittee shall keep records of the number of batches run each month in the bonding operation of Source ID P121 and the amount of acetone used each month in the bonding operation of Source ID P121. The records shall be used to verify compliance with the acetone limitation.

(b) All records generated pursuant to this condition shall be generated and complete no later than 15 calendar days after the end of each month (for example, the record covering the 12-consecutive month period beginning at the start of August 2023 through the end of July 2024 shall be generated and completed by August 15, 2024).

(c) All records generated pursuant to this condition shall be retained for a minimum of five years and shall be made available to the Department upon request.

**SECTION D. Source Level Requirements****V. REPORTING REQUIREMENTS.**

No additional reporting requirements exist except as provided in other sections of this permit including Section B (State Only General Requirements).

**VI. WORK PRACTICE REQUIREMENTS.**

**# 006 [25 Pa. Code §127.441]**

**Operating permit terms and conditions.**

The blending operation and the bonding operation of Source ID P121 shall not operate simultaneously.

**# 007 [25 Pa. Code §127.441]**

**Operating permit terms and conditions.**

The blending operation or bonding operation of Source ID P121 shall not simultaneously run with the operation of Source ID P106.

**VII. ADDITIONAL REQUIREMENTS.**

**# 008 [25 Pa. Code §127.441]**

**Operating permit terms and conditions.**

The permittee shall control the air contaminant emissions from Source ID P121 with the Donaldson model DFO UW ultra-web media cartridge collector (Control Device ID C4). The permittee shall collect all the air contaminants from all points of loading and mixing as described in the Request for Determination approved on June 8, 2006 and September 27, 2016.

**# 009 [25 Pa. Code §127.441]**

**Operating permit terms and conditions.**

Source ID P121 consists of the blending and bonding operations associated with sample product manufacturing as described in the Request for Determination of Requirement for Plan Approval approved on June 8, 2006.

The permittee shall control the air contaminant emissions from Source ID P121 with the Donaldson model DFO UW ultra-web media cartridge collector (Control Device ID C4), authorized via Request for Determination on September 27, 2016.

**# 010 [25 Pa. Code §127.441]**

**Operating permit terms and conditions.**

The permittee shall only use acetone as the solvent used in the sample production operations associated with Source ID P121.

**SECTION D. Source Level Requirements**

Source ID: P122

Source Name: 50 KW EMERGENCY GENERATOR

Source Capacity/Throughput:

**I. RESTRICTIONS.****Emission Restriction(s).**

# 001 [25 Pa. Code §123.13]

**Processes**

The concentration of particulate matter in the exhaust of Source ID P122 shall not exceed 0.04 grains per dry standard cubic foot of effluent gas volume.

# 002 [25 Pa. Code §123.21]

**General**

The concentration of sulfur oxides, expressed as sulfur dioxide (SO<sub>2</sub>), in the exhaust from Source ID P122 shall not exceed 500 parts per million, by volume, dry basis.

**Fuel Restriction(s).**

# 003 [25 Pa. Code §127.441]

**Operating permit terms and conditions.**

Source ID P122 shall be fired on #2 fuel oil only.

**Operation Hours Restriction(s).**

# 004 [25 Pa. Code §127.441]

**Operating permit terms and conditions.**

The permittee shall not operate Source ID P122 more than 500 hours in any 12 consecutive month period as described in the Request for Determination of Requirement for Plan Approval (RFD) approved by the Department on September 24, 1999.

**II. TESTING REQUIREMENTS.**

No additional testing requirements exist except as provided in other sections of this permit including Section B (State Only General Requirements).

**III. MONITORING REQUIREMENTS.**

No additional monitoring requirements exist except as provided in other sections of this permit including Section B (State Only General Requirements).

**IV. RECORDKEEPING REQUIREMENTS.**

# 005 [25 Pa. Code §127.441]

**Operating permit terms and conditions.**

(a) The permittee shall keep comprehensive and accurate records of the number of hours Source ID P122 operates each month as described in the Request for Determination of Requirement for Plan Approval (RFD) approved by the Department on September 24, 1999.

**SECTION D. Source Level Requirements**

(b) All records generated pursuant to this condition shall be generated and complete no later than 15 calendar days after the end of each month (for example, the record covering the 12-consecutive month period beginning at the start of August 2023 through the end of July 2024 shall be generated and completed by August 15, 2024).

(c) All records generated pursuant to this condition shall be retained for a minimum of five years and shall be made available to the Department upon request.

**# 006 [40 CFR Part 63 NESHAPS for Source Categories §40 CFR 63.6655]**

**Subpart ZZZZ - National Emissions Standards for Hazardous Air Pollutants for Stationary Reciprocating Internal Combustion Engines**

**What records must I keep?**

The permittee shall comply with the applicable recordkeeping requirements in 40 CFR Sections 63.6655(a), (d), and (e).

**V. REPORTING REQUIREMENTS.**

**# 007 [40 CFR Part 63 NESHAPS for Source Categories §40 CFR 63.13]**

**Subpart A--General Provisions**

**Addresses of State air pollution control agencies and EPA Regional Offices.**

The submission of all requests, reports, applications, submittals and other communications required by 40 CFR Part 63 Subpart ZZZZ, Sections 63.6580 through 63.6675 shall be submitted to both the U. S. Environmental Protection Agency and the Department. The Environmental Protection Agency copies may be sent to:

R3\_Air\_Apps\_and\_Notices@epa.gov

And

United States Environmental Protection Agency  
Region III, Air and Radiation Division  
Permits Branch (3AD10)  
Four Penn Center  
1600 John F. Kennedy Boulevard  
Philadelphia, Pennsylvania 19103-2852

And

The Pennsylvania Department of Environmental Protection  
Air Quality Program Manager  
208 W. Third Street, Suite 101  
Williamsport, PA 17701-6448

**# 008 [40 CFR Part 63 NESHAPS for Source Categories §40 CFR 63.6645]**

**Subpart ZZZZ - National Emissions Standards for Hazardous Air Pollutants for Stationary Reciprocating Internal Combustion Engines**

**What notifications must I submit and when?**

The permittee shall comply with the applicable notification requirements in 40 CFR Section 63.6645(a).

**VI. WORK PRACTICE REQUIREMENTS.**

**# 009 [25 Pa. Code §127.441]**

**Operating permit terms and conditions.**

Source ID P122 shall be equipped with a non-resettable hour meter to record the number of hours of operation as described in the Request for Determination of Requirement for Plan Approval (RFD) approved by the Department on September 24, 1999.

**# 010 [40 CFR Part 63 NESHAPS for Source Categories §40 CFR 63.6603]**

**Subpart ZZZZ - National Emissions Standards for Hazardous Air Pollutants for Stationary Reciprocating Internal Combustion Engines**

**SECTION D. Source Level Requirements**

**What emission limitations, operating limitations, and other requirements must I meet if I own or operate an existing stationary RICE located at an area source of HAP emissions?**

The permittee shall comply with the applicable operating requirements specified in 40 CFR Section 63.6603(a).

**# 011 [40 CFR Part 63 NESHAPS for Source Categories §40 CFR 63.6625]**

**Subpart ZZZZ - National Emissions Standards for Hazardous Air Pollutants for Stationary Reciprocating Internal Combustion Engines**

**What are my monitoring, installation, operation, and maintenance requirements?**

The permittee shall comply with the applicable monitoring, installation, collection, operation, and maintenance requirements in 40 CFR Sections 63.6625(e), (f), (h), and (i).

**VII. ADDITIONAL REQUIREMENTS.**

**# 012 [25 Pa. Code §127.441]**

**Operating permit terms and conditions.**

one Katolight Standby Power Systems model D50 FRH4 #2-fuel-oil fired emergency generator (50 KW); exempted from plan approval via Request for Determination submittal on September 24, 1999.

**# 013 [40 CFR Part 63 NESHAPS for Source Categories §40 CFR 63.6585]**

**Subpart ZZZZ - National Emissions Standards for Hazardous Air Pollutants for Stationary Reciprocating Internal Combustion Engines**

**Am I subject to this subpart?**

Source ID P122 is subject to the requirements of 40 CFR Part 63 Subpart ZZZZ, Sections 63.6580 through 63.6675. The permittee shall comply with all applicable requirements specified in 40 CFR Part 63 Subpart ZZZZ Sections 63.6580 through 63.6675.

**# 014 [40 CFR Part 63 NESHAPS for Source Categories §40 CFR 63.6605]**

**Subpart ZZZZ - National Emissions Standards for Hazardous Air Pollutants for Stationary Reciprocating Internal Combustion Engines**

**What are my general requirements for complying with this subpart?**

The permittee shall comply with the applicable general requirements in 40 CFR Section 63.6605.

**# 015 [40 CFR Part 63 NESHAPS for Source Categories §40 CFR 63.6630]**

**Subpart ZZZZ - National Emissions Standards for Hazardous Air Pollutants for Stationary Reciprocating Internal Combustion Engines**

**How do I demonstrate initial compliance with the emission limitations and operating limitations?**

The permittee shall comply with the applicable compliance demonstration requirements in 40 CFR Section 63.6630(c).

**# 016 [40 CFR Part 63 NESHAPS for Source Categories §40 CFR 63.6640]**

**Subpart ZZZZ - National Emissions Standards for Hazardous Air Pollutants for Stationary Reciprocating Internal Combustion Engines**

**How do I demonstrate continuous compliance with the emission limitations, operating limitations, and other requirements?**

The permittee shall comply with the applicable continuous compliance demonstration requirements in 40 CFR Sections 63.6640(a), (b), and (f).



**SECTION E. Source Group Restrictions.**





**SECTION F. Alternative Operation Requirements.**

No Alternative Operations exist for this State Only facility.



**SECTION G. Emission Restriction Summary.**

No emission restrictions listed in this section of the permit.

**SECTION H. Miscellaneous.**

(a) The following air contaminant sources are considered to be insignificant in regards to air contaminant emissions and have been determined by the Department to be exempt from permitting requirements. However, this determination does not exempt the sources from compliance with all applicable Federal and State regulations and all applicable air quality regulations specified in 25 Pa. Code Chapters 121-145:

- (1) rotomill and baghouse(s); exempted from plan approval per an August 27, 1997 and revised September 27, 2007 Department determinations
- (2) hydrogen/propane tank (FM04) (6,000 pounds)
- (3) spencer turbine vacuum system (20 HP); exempted from plan approval per a August 27, 1997 Department determination
- (4) horizontal storage tank (50 gallons); exempted from plan approval per a August 27, 1997 Department determination
- (5) battery charging operation/ventilation fan (1500 acfm); exempted from plan approval via Request for Determination submittal on July 15, 1997
- (6) three (3) #2 fuel oil storage tanks having 15,000 gallon, 10,000 gallon and 6,000 gallon storage capacities, respectively; exempted from plan approval via Request for Determination submittal on September 1, 1999 (FM01, FM02 and FM03)
- (7) one (1) ethylene glycol storage tank (2,200 gallons); exempted from plan approval via Request for Determination submittal on September 1, 1999.
- (8) one portable dust sweeper in the Manufacturing building; exempted from plan approval via Request for Determination approved by the Department on November 18, 2011.
- (9) Process Room Ventilation System associated with Source ID. P102; exempted from plan approval via Request for Determination submittal on September 7, 1999
- (10) portable propane-operated vacuum system
- (11) forktrucks
- (12) propane cylinders for portable vacuum and forktrucks
- (13) lab spectrometer and associated argon (90%) and methane (10%) gas canisters
- (14) Model 2701X Electric Arc Button furnace
- (15) portable dust collector exempted from plan approval on September 10, 2003
- (16) portable dust collector in the Sample production process exempted from plan approval via Request for Determination approved by the Department on November 18, 2011

(b) Revision no. 1 issued on September 2, 2005 is a minor operating permit modification to incorporate into the operating permit a number of process modifications and equipment installations that Hoeganaes performed from 1994 through 2002 without prior Department approval during that time period. This revision also includes the following sources that have been exempted from plan approval: construction of an AGM delivery system (Source ID P112) to the VT-4200 mixer approved on December 2, 2004, construction of a Distaloy screen system approved on March 10, 2005 and construction of an AncorBond III process approved on May 12, 2005.

(c) Revision no. 2 issued on December 22, 2016, is a minor operating permit modification to incorporate into the operating permit Control Devices C1, C2, C3, and C4 authorized via Request for Determination on September 27, 2016. These control devices replaced collector C15, C16, C17, C18, C19, and C35 (associated with P101) and C32, C33, and C34 (associated with P106).



\*\*\*\*\* End of Report \*\*\*\*\*

---